

## SECTION 7 - POWER WIRING

The DeltaMax driver and motors have three basic power wiring configurations. Each of the configurations is shown in the following power wiring diagrams (**Figures 7.2 through 7.4**). Each of the diagrams shows recommended circuit breaker, contactor and wire gauge.

### 7.1 CIRCUIT BREAKER

It is recommended that each driver be provided with a circuit breaker for protection of the driver and motor. All of the drives are suitable for use on a circuit capable of delivering not more than 5000 rms symmetrical amperes, 240 vac maximum when protected by a circuit breaker having an interrupting rating not less than 5000 rms symmetrical amperes, 240 volts maximum. Each of the driver wiring diagrams contains a chart of the recommended circuit breaker for each driver size.

The breaker is sized for the worst-case maximum power draw of the driver at the worst-case low line voltage. The charts contain specific vendor and size recommendations. Other types of circuit breakers or fuses may be used provided the continuous ratings are equivalent, the instantaneous rating is 10 to 15 times continuous and can support 3 times continuous for at least 3 seconds.

Lower rating protection devices may be used that is sized for the motor power rating. Contact the IIS factory for specific recommendations.

### 7.2 CONTACTOR

The DMAX-1.5 through DMAX-17.5 driver sizes has an internal power bus contactor. The DMAX-35 through DMAX-115 sizes requires an external power bus contactor. The driver-wiring diagram for the larger size drivers contains a chart of the recommended contactor for each driver size.

The contactor is sized for the worst-case maximum power draw of the driver at the worst-case low line voltage. The charts contain specific vendor and size recommendations. Other types of contactors may be used provided the continuous ratings are equivalent and the maximum instantaneous rating is 10 to 15 times continuous. The driver is equipped with a soft start circuit to limit the contactor inrush current.

The coil voltage should be the same rating as the incoming line. The maximum current draw for the coil cannot exceed 0.25 amps. The contactor coil must be fitted with a transient voltage protection device. An RC type suppression device is preferred.

### 7.3 WIRE SIZES

It is required that each driver be installed with the appropriate size wire for proper operation. Each of the driver wiring diagrams contains a chart of the recommended wire gauges and terminal connection tightening torques for each driver size.

The wire is sized for the worst-case maximum power draw of the driver at the worst-case low line voltage. The charts contain specific METRIC and AWG size recommendations for stranded wire. Use only copper wire rated for 60/75 degree C or greater. The driver terminals are specifically designed to handle the recommended wire gauge with lug or ferrule terminations. See wiring diagrams for more details.

## 7.4 TRANSFORMERS

Isolating the driver from the facility power line with a transformer is recommended but not required. A transformer may be required to step down or step up the facility power line to meet the driver voltage specifications in [Section 3](#).

If a transformer is used, select a transformer with the following characteristics:

- Isolation type.
- Load regulation less than 10%.
- Ability to provide 3 times rated current for 3 to 5 seconds without saturation.
- Ability to drive load with a power factor of 0.85.
- Primary or secondary taps to provide -10%; nominal; +10%; supply voltage.

To achieve maximum performance from the driver, the power input to the driver should be as close to nominal driver input voltage rating as possible. The facility line voltage varies through wide ranges in many parts of the world and it is recommended to match the nominal facility voltage to the nominal input voltage rating of the driver with a transformer. This gives the system the maximum operating range with facility line voltage fluctuations.

If the line voltage is too low, intermittent under voltage alarms may occur. A high line voltage will result in excessive regeneration dumping or intermittent over voltage alarms.

Buck boost transformers may be used to optimally match the facility line voltage to the driver line voltage rating. Buck boost transformers can be used with or without an isolation transformer. If buck boost transformers are used in conjunction with an isolation transformer, it is best to put the buck boost transformers on the primary side of the isolation transformer.

As a general rule the transformer rating can be calculated using the following formulas:

### For single phase transformer:

$$\text{Transformer Capacity (VA)} = \frac{\text{Rated Mechanical Output (Watts)}}{0.7}$$

Where: Rated Mechanical Output is from DeltaMax Package rating.  
 0.7 = motor/drive efficiency and single phase full wave rectifier factor

Example: Select transformer for a DeltaMax-200HRA motor/drive package

$$\text{Transformer Capacity (VA)} = \frac{200}{0.7} = .285 \text{ VA}$$

### For three phase transformer:

$$\text{Transformer Capacity (Watts)} = \frac{\text{Rated Mechanical Output (Watts)}}{0.85}$$

Where: Rated Mechanical Output is from DeltaMax Package rating.  
 0.85 is motor/drive efficiency and three phase rectifier factor

Example: Select transformer for a DeltaMax-6500HRA motor/drive package

$$\text{Transformer Capacity (VA)} = \frac{6500}{0.85} = 7647 \text{ Watts}$$

## **7.4 TRANSFORMERS (cont'd)**

One transformer can supply multiple motor/driver packages. Simply add the rated mechanical output of the motor/driver packages together and use the above formulas. If one transformer is used to supply multiple drivers, be sure to protect each driver with the appropriate circuit breaker or fuse.

IIS offers a full line of transformers for various line voltage and frequencies, enclosed and open frame types. Contact IIS Application Engineering Department for full details.

## **7.5 BRANCH CIRCUIT PROTECTION FOR CONTROL VOLTAGE R0,S0**

The DMAX-35 through DMAX-115 requires a separate control voltage supply (R0 S0) for proper operation. The R0 S0 circuit is fused internal to the driver and need not be externally fused except to protect the control voltage wiring external to the driver using branch circuit protection guidelines. The control voltage circuit of multiple drivers can be fed from a single branch circuit.

## 7.6 WIRING PRACTICES AND GROUNDING

All wiring must conform to accept standards such as NEMA and NEC codes. Signal and low voltage I/O wires must be physical separated from high voltage wires by at least 12 inches or separated by a suitable barrier such as steel conduit or wiring trough separator.

The driver must be adequately grounded for proper operation and to provide personnel safety. The proper grounding technique is shown in **Figure 7.1** below.

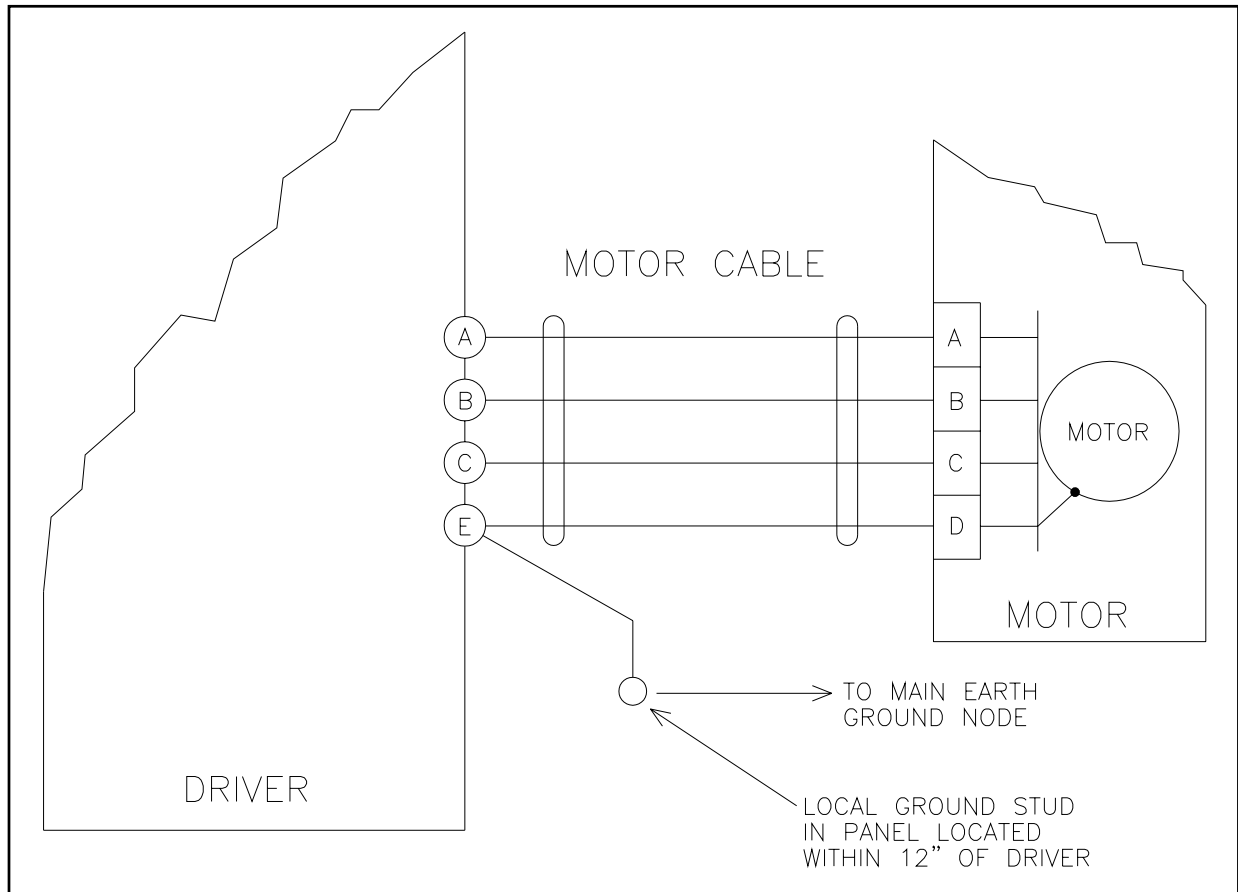

**Figure 7.1 - Grounding Technique**

### NOTE

Multiple drivers can share a local ground stud if it is located within 12" of each driver's (E) terminal. The ground symbol on each drive indicates that a connection must be made between the (E) terminal of the drive and earth ground.



## 7.7 POWER SEQUENCING

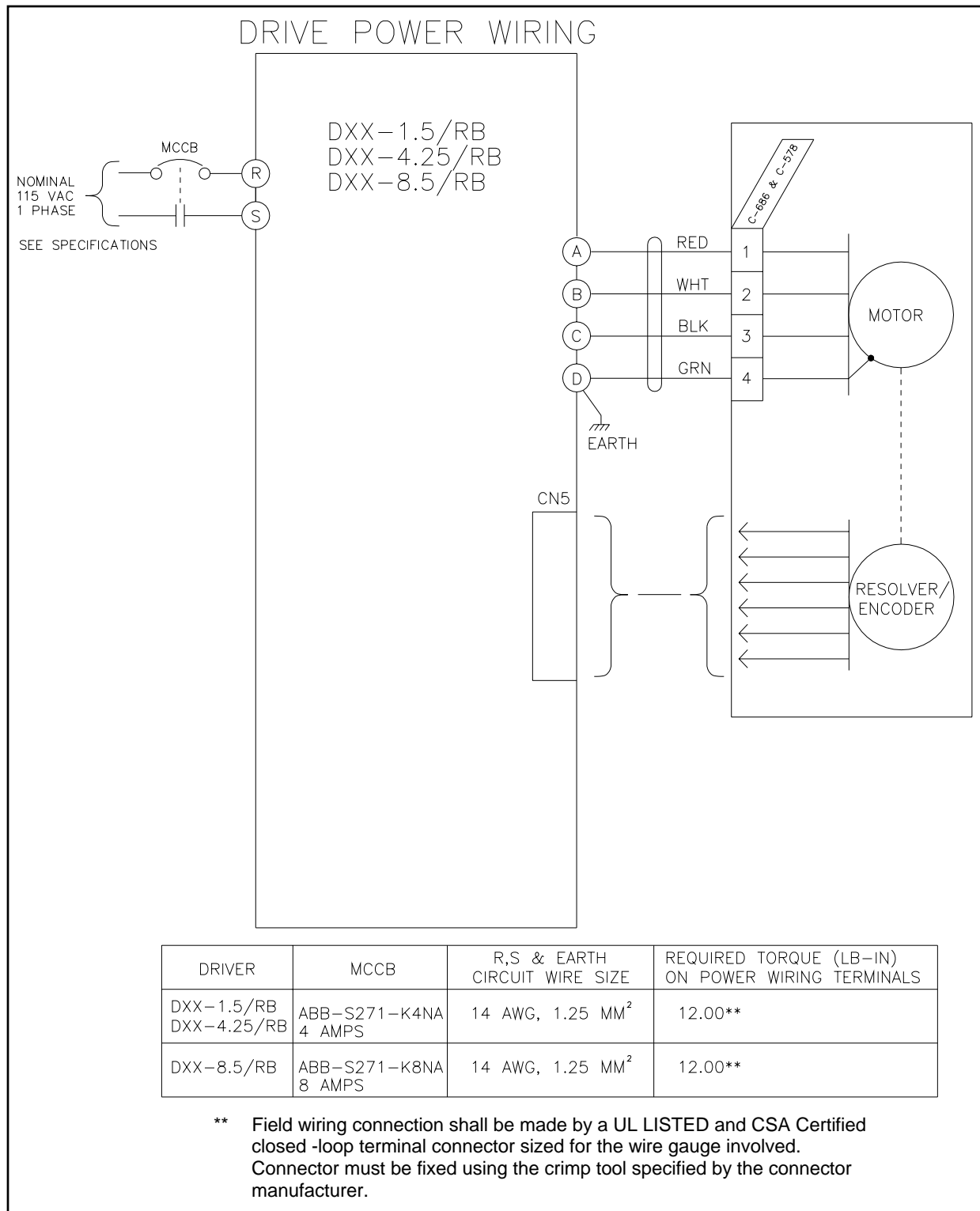

**Figure 7.2 - DMAX-1.5/RB Through DMAX-8.5/RB Power Wiring**

### 7.7 POWER SEQUENCING (cont'd)

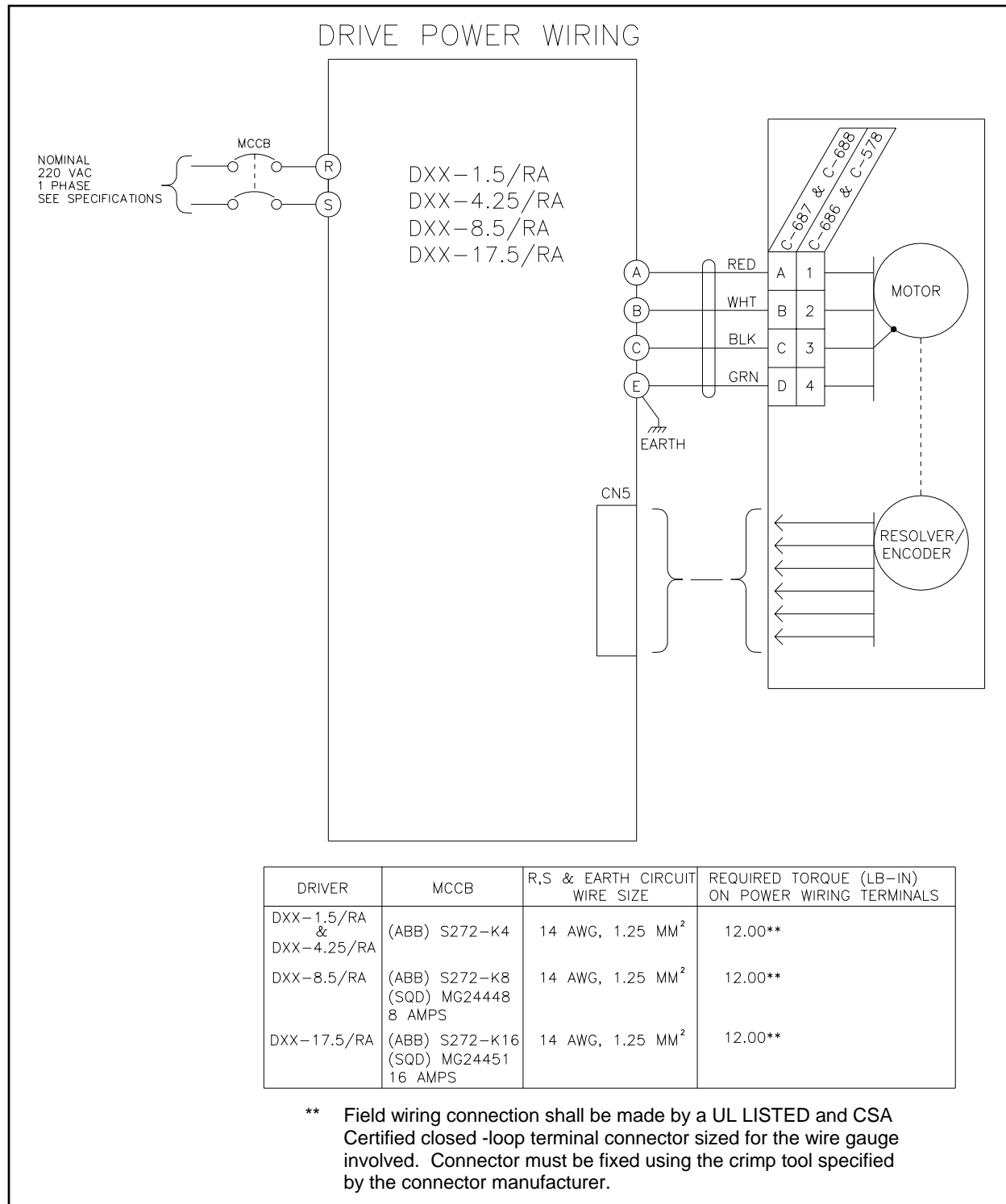
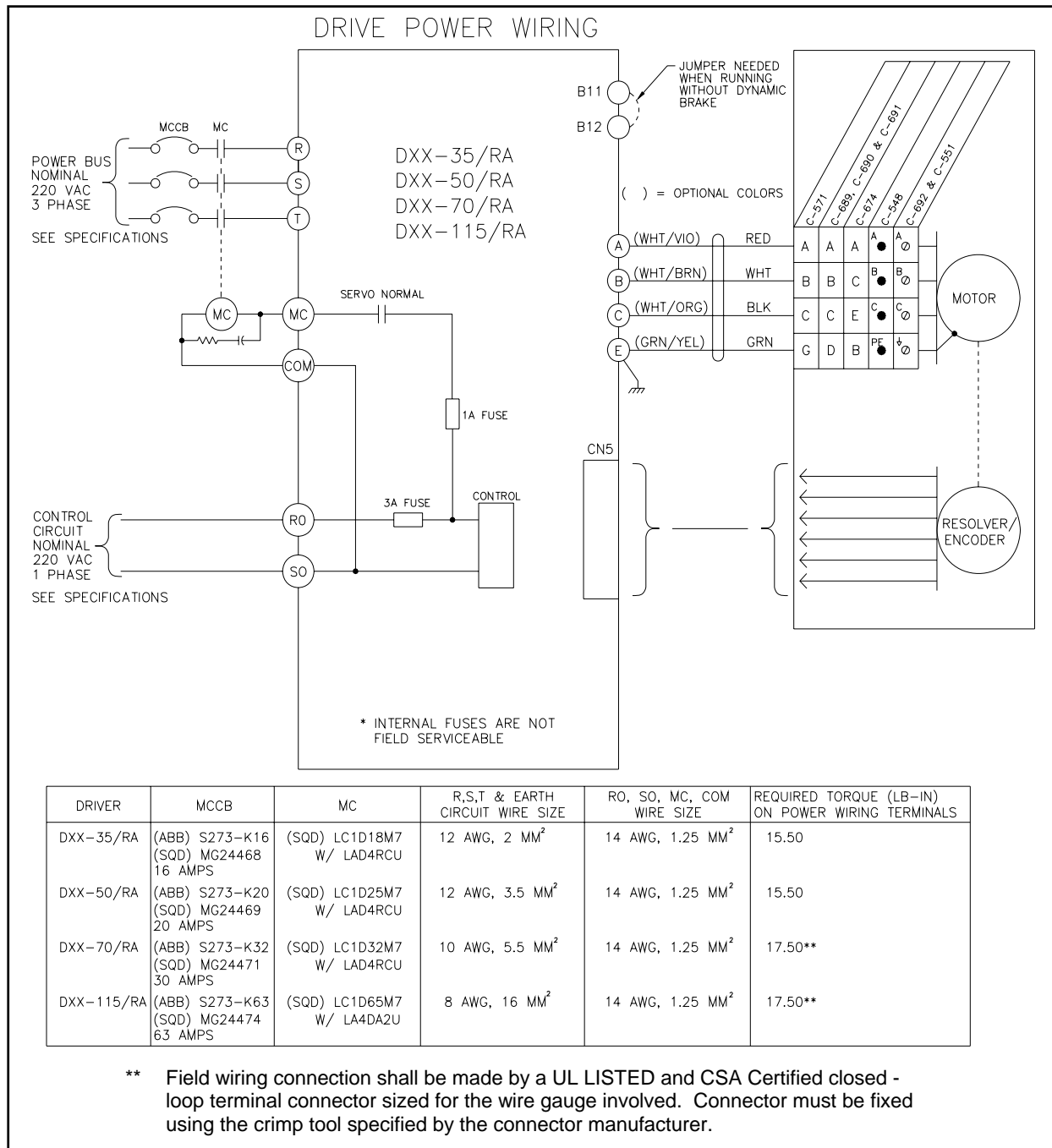

Figure 7.3 - DMAX-1.5/RA Through DMAX-17.5/RA Power Wiring

### 7.7 POWER SEQUENCING (cont'd)



**Figure 7.4 - DMAX-35/RA Through DMAX-115/RA Power Wiring**

