







SECTION 4 - KEYPAD PROGRAMMING

The Delta S Driver is a fully digital driver that has a rich set of motion control building blocks that are configurable using the driver's software. A built in keypad and display can be used to set internal parameters that configure the driver's software.

An easy to use menu scheme allows the user to:

- Activate optional features
- Monitor key parameters and alarms
- Adjust driver parameters
- Manual or automatic tuning of the motor and driver
- Manual testing of driver operation

The drivers' keypad and display are shown in **Figure 4.1**. The functions are as follows:

- **LED DISPLAY** is a 5-digit unit that displays coded messages, alarms and parameter values. Messages are displayed in coded bit patterns, hexadecimal, decimal and coded letters.
- **UP-ARROW**  is used to navigate around the minor menu loops, to increase the value of a parameter and in combination with other keys for special functions.
- **DOWN-ARROW**  is used to navigate around the minor menu loops, to decrease the value of a parameter and in combination with other keys for special functions.
- **SELECT**  is used to identify which digit of the display is selected for modification (flashing). This key is also used in combination with the **CONFIRM**  key to prepare a parameter for modification.
- **MODE**  is used to navigate the main menu loop and to return to the main menu loop from the minor loops.
- **CONFIRM**  is used to confirm a parameter value and to set into non-volatile memory and to reset alarms. This key is also used in combination with the **SELECT**  key to prepare a parameter for modification.
- **FLASHING DECIMAL POINT** indicates that an alarm is active.

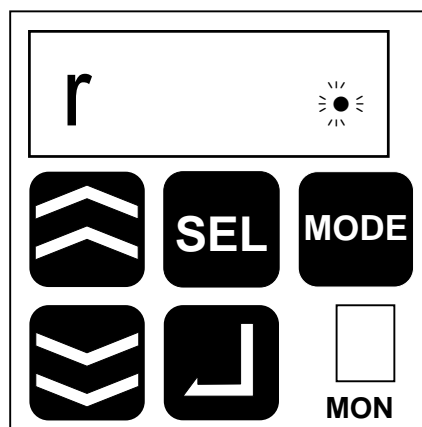









Figure 4.1 - Delta S Driver Keypad and Display







4.1 NAVIGATING THE DRIVER'S MENU

The menu structure for programming the driver consists of a main menu loop with several minor menu loops and the Special Menu. The main menu loop and partial sections of the minor loops are shown in [Figure 4.2](#).

The major loop is shown vertically on the left side of the diagram. There are four major items on the main menu loop. Each of these items are the starting point for minor menu loops.

- **STATUS DISPLAY** minor menu loop contains drive and motor status displays such as motor speed, motor position, following error, etc.
- **DIAGNOSTIC DISPLAY** minor menu loop provides diagnostic information such as I/O status, alarms and alarm history.
- **ADJUST PARAMETER** minor menu loop contains parameters that are typically adjusted by the user. Parameters include speed scaling, servo tuning values and load inertia setting.
- **USER PARAMETER** minor menu loop contains basic configuration parameters that are usually set once per application such as control mode, motor type, electronic gear ratio and analog polarity.
- **HP PARAMETER** is a sub-menu loop from the **USER PARAMETER** minor menu. This sub-menu loop also contains configuration parameters that are less frequently used or modified.

The  key is used to move around the main menu loop. Once the main menu is positioned on the first parameter of a minor loop the  and  keys are used to move around the minor menu loop. When in the minor menu loop the  and  or the  and  keys move through the parameters in jumps of 10 rather than 1. The  mode key can be used to move from anywhere in the minor menu back to the main menu loop.

The HP parameter sub-menu is entered by putting the main menu loop on UP-02 and pressing and holding the  key then pressing both the  and  keys. Once in the HP sub-menu the  and  keys are used to move around the sub-menu. The  must be pressed twice quickly to move from the HP sub-menu back to the UP minor menu.

The Special Function Menu is used for Auto Tuning, manual jogging of the motor and forcing outputs. [Section 4.3](#) describes the Special Function Menu.

4.1 NAVIGATING THE DRIVER'S MENU (cont'd)

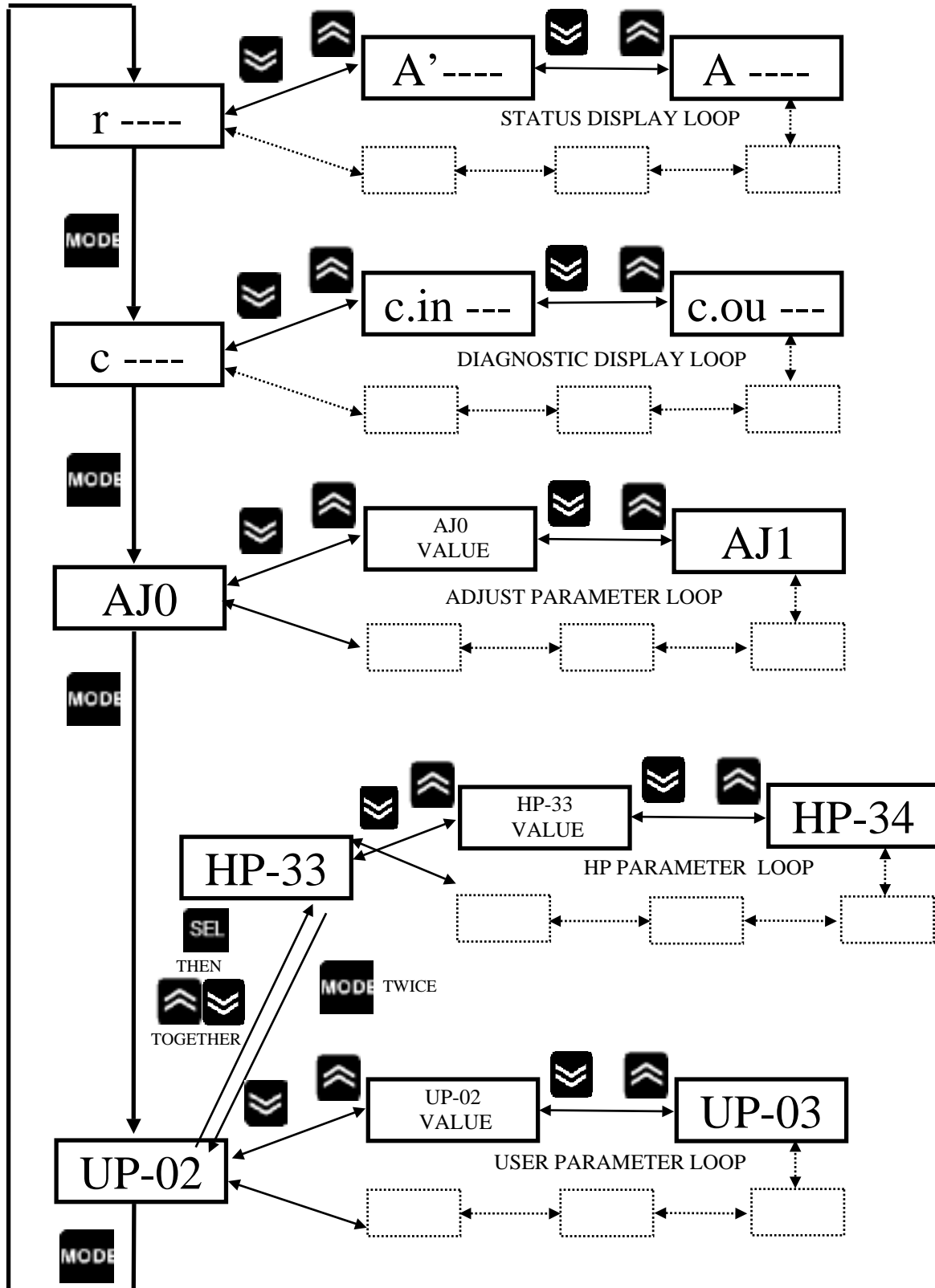

Figure 4.2 - Main Menu Loop and Minor Loops

4.1.1 STATUS DISPLAY MENU LOOP

The Status Display Menu Loop provides a real time display of motor and driver status. The display format uses the left most digits for a coded message of the item to be displayed and the right most digits are the value. The coded item on the left will flash indicating negative (-) value. The sign convention is (+) is CCW and (-) is CW.

Some of the display values, such as A' & A, are too large for a single display so they are broken into two sections and are displayed on two successive menu displays. The prime (') symbol indicates the upper four (4) digits or most significant section and the non-prime symbol indicates lower four (4) digits. For example, if successive displays reads [A' 1466] and [A 6789], the ACTUAL POSITION is 14666789.

Parameters can only be read in the Status Display Menu. The driver is set to the (r) Motor Speed at power application. Any alarm will overwrite the display.

The Status Display Menu is organized as follows:

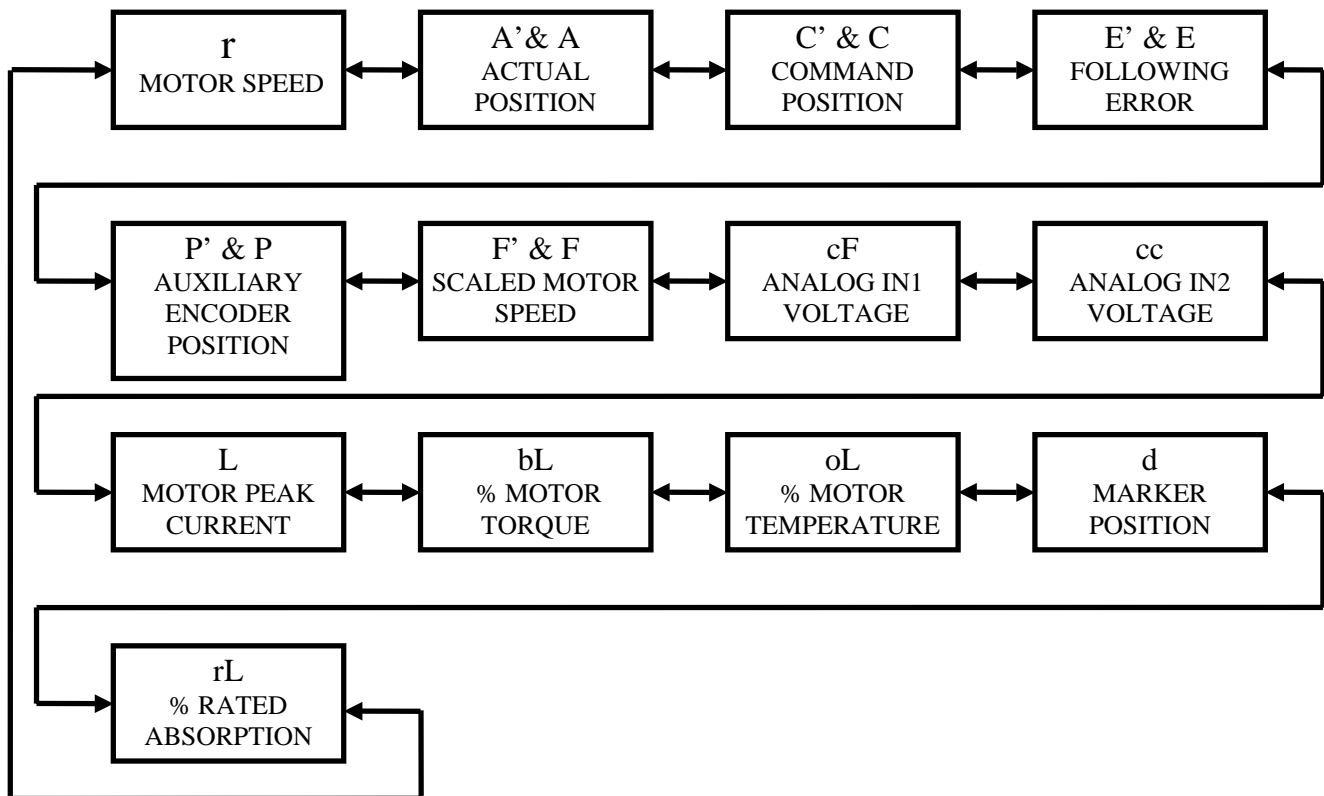

4.1.1 STATUS DISPLAY MENU LOOP (cont'd)

Status Display Descriptions:

DISPLAY ITEM	SYMBOL	RANGE & UNITS	CONTENTS
Motor rpm	r	±4000 RPM	Displays the speed of motor.
Actual Position	A' A	±9999999 Bits	Displays the actual position of the motor. With resolver feedback, the 0.0 position at power up is referenced to the nearest resolver 0.0. The Delta motors have a 2X resolver, and have two 0.0 points or markers per motor shaft rotation. When the count exceeds display range, 9999999 appears.
Command Position	C' C	±9999999 Bits	Displays the command position of the driver (scaled by UP-05/UP-04 similar to A' A above). When the count exceeds display range, 9999999 appears.
Following Error	E' E	±9999999 Bits	Displays the difference between command position and actual position. Used in position control mode only.
Auxiliary Encoder Pulse Position	P' P	+32767~32768 Pulses	Displays the auxiliary encoder position register. This counter is a signed 16-bit counter with a range of +32767 to -32768. Counter rolls over when it reaches the maximum count (ring counter).
Scaled Motor Speed	F' F	±9999999 RPM	Displays the speed of the motor scaled by HP-41/HP-42. This used typically used to display "machine speed" if the speed exceeds display range, 9999999 appears.
Analog In1 Voltage	cF	±10.0 V	Displays the input voltage for Analog Input 1.
Analog In2 Voltage	cc	±10.0 V	Displays the input voltage for Analog Input 2
Motor Peak Current	L	±160.0 A (peak)	Displays the output current to motor. "A (peak)" shows the peak value of AC current.
% Motor Torque	bL	0~255%	Displays the load ratio (output torque/rated torque) * 100%. The time constant for calculating this ratio is set by HP-33.
% Motor Temperature	oL	0~110%	Displays calculated motor temperature as a % of the maximum rating. The electronic motor thermal limit alarm activates at 110% (AL-17). oL initializes to 90% at power on.
Marker Position	d	0~359.9 deg	Displays the motor shaft angle from the motor marker ZPD position. The driver has N marker ZPD positions depending on the resolver/encoder installed in the motor. (i.e. a motor with a 2X resolver has 2 ZPD positions per motor revolution, see motor drawings in Appendix A.6, A.7 & A.8). If the motor has 3X resolver and 3 ZPD positions, this display will go from 0.0 to 359.9 degrees 3 times per motor rotation.
% Rated Absorption	rL	0~100%	For DS-1.5, DS-4.25, DS-8.5 and DS-17.5 the display is (motor absorption torque/motor rated torque) * 100%. For DS-35 and up the display is % rating of the regeneration resistor capacity (UL-31).

4.1.2 DIAGNOSTIC DISPLAY MENU LOOP

The Diagnostic Display Menu Loop provides a real time display of I/O points, alarms, alarm history and driver configurations. The display format uses the left most digits for a coded message of the item to be displayed and the right most digits are the value.

Some of the display values, such as A.L-H ALARM HISTORY require additional keystrokes to view the complete status. The additional keystrokes are described in the individual display descriptions.

Parameters can only be read in the Diagnostic Display Menu, with the exception that the ALARM HISTORY can be cleared.

The Diagnostic Display Menu Loop is organized as follows:

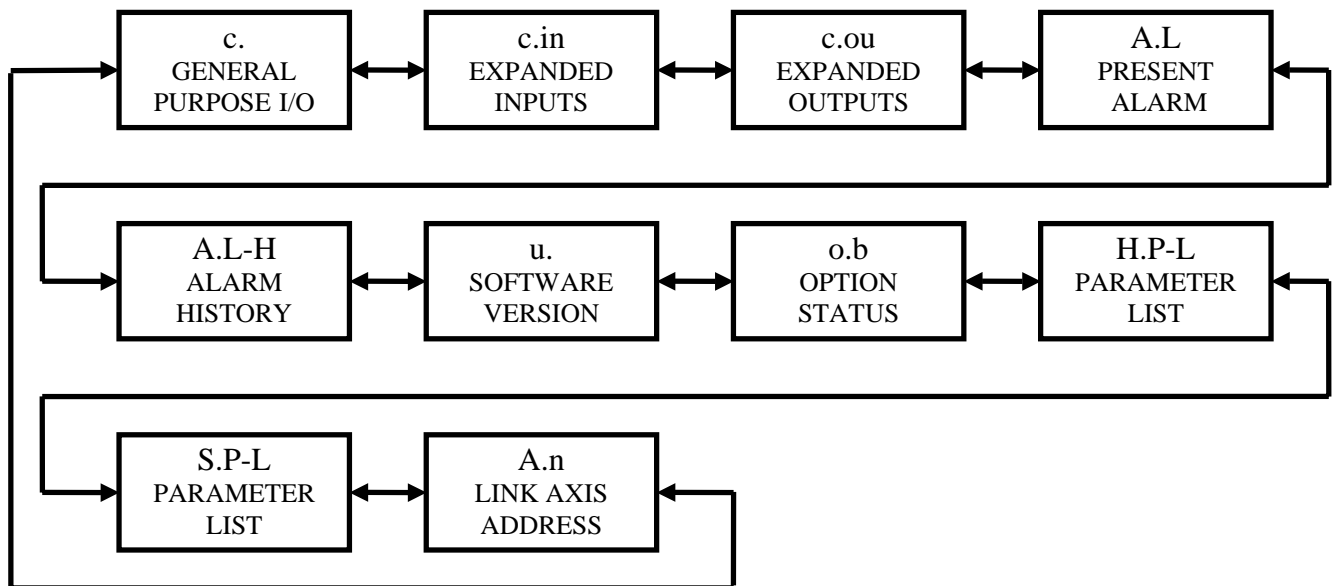



























Diagnostic Display Descriptions:



DISPLAY ITEM	SYMBOL	CONTENTS
General purpose I/O	c.	Displays the current I/O status using the vertical segment bars in the display. The top half of the segment bar are inputs and the bottom half are outputs. The right most vertical bar is IN1 (top half) and OUT1 (bottom half). The vertical bar just to the right of the c. is IN8 (top half) and OUT8 (bottom half). When the bar is illuminated the I/O point is ON. The I/O point can be inverted using HP-44 & HP-45. See the individual signal level I/O diagrams in Section 7 . <div style="text-align: center;"> IN8 IN1 OUT8 OUT1 </div> <p>NOTE: The IN9-IN16 and OUT9-OUT16 status cannot be viewed on display.</p>
General Purpose Input	c.in	Not used.
General Purpose Output	c.out	Not used.

4.1.2 DIAGNOSTIC DISPLAY MENU LOOP (cont'd)

Diagnostic Display Descriptions (cont'd):

DISPLAY ITEM	SYMBOL	CONTENTS
Alarm	A.L	Displays the current alarm if present. A.L with no numbers indicates that there is no current alarm. A.L # indicates a current alarm code #. Most alarms can be reset with the  key. See Section 12 for alarm code descriptions and reset method.
Alarm History	A.L-H 0-E	<p>Displays the alarm history log for the previous 15 alarms. When  key and  key are concurrently pressed, the AL-H display changes to N.- #, where N is the position of the alarm in the history log (0 most current, E oldest) and # is the alarm code. The history log can be scrolled forward and backward using the  and  keys. The  key returns to the A.L-H display.</p> <p>Clearing the complete alarm history is possible with software revision 10 and above. To clear the alarm history, use the    keys to navigate the menu until the A.L-H is in the display.</p> <ul style="list-style-type: none"> Concurrently press the  and  keys and the display changes to N.- #. Concurrently press the  and  keys while holding down the  key and the display changes to AHcLr. Concurrently press the  and  and the display starts flashing indicating alarm clearing, then press  to complete the clearing procedure. <p>Double clicking  goes back to 0.- and another press of  returns to A.L-H.</p>
Software Version	u.	Displays the revision of the operating system software.
Option Status	o.b	Displays the status of any option modules installed. 04: No options 06: 14 bit A/D converter
HP Parameter Change History	H.P-L	Displays a history of the HP parameters that have been changed. When  key and  key are concurrently pressed the display changes to a list of HP-# parameters that have been changed. The history log is 65 deep. The history log can be scrolled forward and backward using the  and  keys.
SP Parameter Change List	S.P-L	Displays a history of the SP that have been changed. When  key and  key are concurrently pressed the display changes to a list of SP-# parameters that have been changed. The history log is 65 deep. The history log can be scrolled forward and backward using the  and  keys.
Link Axis No.	A.n	Not used.

4.1.3 ADJUSTMENT PARAMETER MENU LOOP

The Adjustment Parameter Menu Loop provides access to setup and tuning parameters that are commonly used. Each parameter is displayed in two successive displays. The coded parameter name appears on the first display and the parameter value appears on the second display. The  key will always move from the parameter-coded name to the parameter value. The  key will always move from the parameter value to the coded parameter name. If the parameter value is negative, a (-) sign appears in the left most digit of the display.







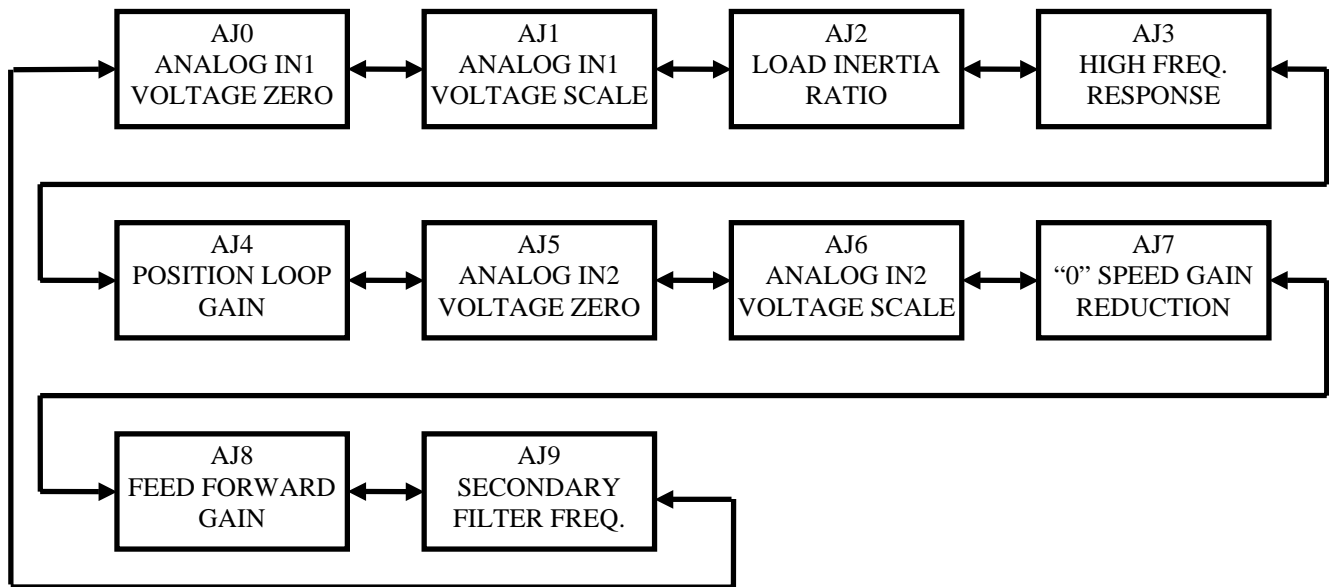



Parameters can be read or written in the Adjust Parameter Menu Loop. The procedure to write into a parameter is found in [Section 4.2](#).









The Adjustment Parameter Menu Loop is organized as follows:





4.1.3 ADJUSTMENT PARAMETER MENU LOOP (cont'd)

ADJUSTMENT PARAMETER	SYMBOL	SETTING RANGE	FACTORY SETTING	DESCRIPTION
ANALOG INPUT 1 VOLTAGE ZERO OFFSET	AJ0	±10.00 V	Factory Preset	<p>Sets the zero offset of the Analog Input 1(AN1). It can be set in two ways:</p> <ol style="list-style-type: none"> 1. Automatically: by concurrently pressing   (all digits flash) and then pressing . The driver will read the analog voltage and create an offset equal and opposite to the analog voltage present at the time. To get a true 0.00 offset, short Analog Input 1 to analog ground before doing the auto zero procedure. 2. Manually: by concurrently pressing   (all digits flash) and then concurrently pressing  . Then adjust the individual digits with .
ANALOG INPUT 1 VOLTAGE SCALER	AJ1	3~40.00 V	10.00V	Sets the voltage desired to obtain full scale on the Analog Input 1 (AN1). For example, if full scale on the analog input is desired at 4.5 VDC input voltage, set AJ1 to 4.50.
LOAD INERTIA RATIO	AJ2	0~100.0	1.0 Times	Sets the baseline frequency response of the driver using the ratio of the load inertia/motor inertia for a rigidly coupled load. If the load is not rigidly coupled, the value entered may vary from the calculated value. If the value is set too high, the motor and driver may become unstable and oscillate. This parameter is set automatically during auto tuning.
HIGH FREQUENCY RESPONSE	AJ3	0.1~20.0	1.0	Sets the high frequency response of the driver. The higher the number the more responsive. If the value is set too high, the motor and driver may become unstable and oscillate. The value in AJ3 is unit less and works in concert with AJ2. This parameter is set automatically during auto tuning.
POSITION LOOP DC GAIN	AJ4	1~200	30 Rad/sec	Sets the DC gain of the position control loop. A higher value in AJ4 results in stiffer, faster response. If the value is set too high, the motor and driver may become unstable and oscillate. This parameter is set automatically during auto tuning.

4.1.3 ADJUSTMENT PARAMETER MENU LOOP (cont'd)

ADJUSTMENT PARAMETER	SYMBOL	SETTING RANGE	FACTORY SETTING	DESCRIPTION
ANALOG INPUT 1 VOLTAGE ZERO OFFSET	AJ5	±10.00 V	Factory Preset	<p>Sets the zero offset Analog Input 2 (AN2). It can be set in two ways:</p> <ol style="list-style-type: none"> 1 Automatically: by concurrently pressing   (all digits flash) and then pressing . The driver will read the analog voltage and create an offset equal and opposite to the analog voltage present at the time. To get a true 0.00 offset, short Analog Input 2 to analog ground before doing the auto zero procedure. 2 Manually: by concurrently pressing   (all digits flash) and then concurrently pressing  . Then adjust the individual digits with .
ANALOG INPUT 2 VOLTAGE SCALER	AJ6	3~40.00 V	10.00V	Set the voltage desired to obtain full scale on the Analog Input 2 (AN2). For example, if full scale on the analog input is desired at 4.5 VDC input voltage, set AJ6 to 4.50.
ZERO SPEED GAIN REDUCTION	AJ7	0~10000	0	Sets the amount of gain reduction at zero speed. The gain is reduced when the motor is below the speed set in UP-08 and at the set values when the speed is above UP-08.
FEED FORWARD GAIN	AJ8	0~2.0 Times	0 Times	Sets the feed forward gain in the position loop. A value of 1.0 results in 0.0 following error. Less than 1.0 will produce a lag between the actual motor position and the commanded position and greater than 1.0 produces a lead. The lead or lag will be proportional to speed at non 1.0 settings.
SECONDARY FILTER	AJ9	100~20000 rad/s	6000 rad/s	Sets the notch frequency of a velocity loop anti-resonance filter. This filter can be used to cancel machine or servo resonance.

4.1.4 USER PARAMETER MENU LOOP

The User Parameter Menu Loop provides access to basic setup parameters that are commonly used. Each parameter is displayed in two successive displays. The coded parameter name appears on the first display and the parameter value appears on the second display. The  key will always move from the parameter-coded name to the parameter value. The  key will always move from the parameter value to the coded parameter name.



Parameters can be read or written in the User Parameter Menu Loop. The procedure to write into a parameter is found in [Section 4.2](#).

The User Parameter Menu Loop is organized as follows:

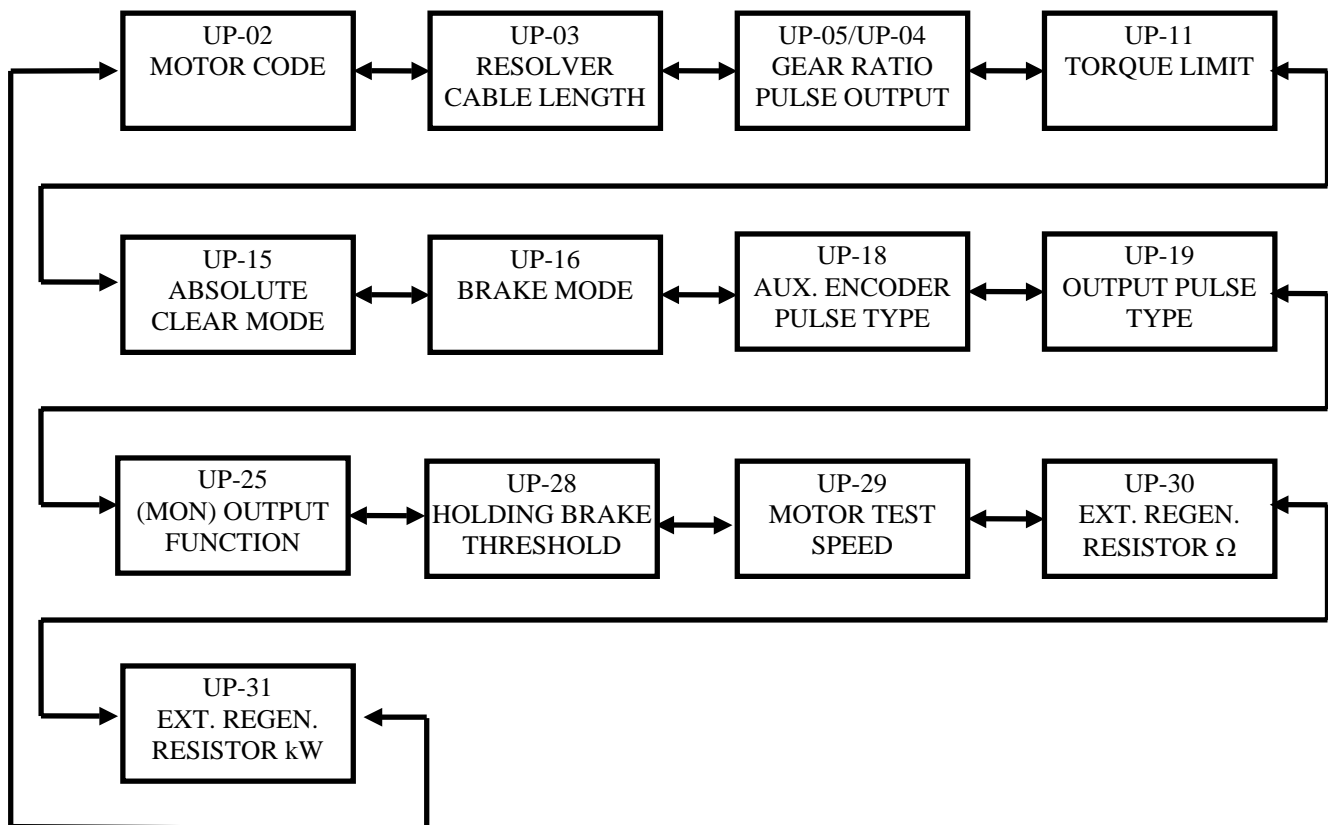

4.1.4 USER PARAMETER MENU LOOP (cont'd)

USER PARAMETER	SYMBOL	SETTING RANGE	FACTORY SETTING	DESCRIPTION
MOTOR CODE	UP-02	0000~FFFF	0000	Sets the internal driver parameters corresponding to the motor code. See Appendix A for motor codes. The driver power must be cycled to register this parameter. Power must be turned OFF then ON for this parameter to take effect.
RESOLVER CABLE LENGTH N/A FOR ENCODER	UP-03	1~120M	5M	Sets the driver resolver cable length compensation.
GEAR RATIO DENOMINATOR FOR THE PULSE OUTPUT	UP-04	1~32767	1	The driver internal feedback resolution is multiplied by the ratio of UP05/UP04 before being sent out the pulse output (APD and BPD). The driver internal command resolution is equal to the number of resolver cycles times 12000 bits/rev or the PPR of the encoder. (i.e. a motor with a 2X resolver has an internal resolution of 24000 bits/rev, see motor drawings in Appendix A.6, A.7 & A.8.)
GEAR RATIO NUMERATOR FOR THE PULSE OUTPUT	UP-05	1~32767	1	See UP-04 Above.
TORQUE LIMIT	UP-11	0~100.0%	100%	When the torque limit is applied the motor torque is limited to the value set in UP-11. UP-11 is % of motor peak torque. See HP-34 for torque limit method.
ABSOLUTE CLEAR MODE	UP-15	0~2	0	Selects the type of home 0.00 processing for absolute systems when the SET "0" POSITION input is energized or upon startup. 0: Makes current position of motor equal to 0.00. 1: Makes the current motor shaft rotation the 0 rotation while preserving the MARKER OFFSET. 2: No effect retains absolute position.
BRAKE MODE	UP-16	0~2	0	Select the type of Brake sequencing to be done when the drive is disabled. 0: No Brake or Dynamic Brake 1 or 2: Mechanical Holding Brake.



4.1.4 USER PARAMETER MENU LOOP (cont'd)

USER PARAMETER	SYMBOL	SETTING RANGE	FACTORY SETTING	DESCRIPTION
AUXILIARY ENCODER INPUT PULSE TYPE	UP-18	00~12	0 0	Sets the type of pulse sequence and polarity of the Auxiliary Encoder Pulse inputs. 00: Pulse, Pulse decoding where FMA increments command position and FMB decrements command position. 01: Quadrature decoding of FMA and FMB with FMA leading FMB for incrementing command position. Quadrature decoding effectively multiplies the input frequency by 4 times. 02: Pulse and direction decoding where FMA is pulse train and FMB is direction. FMB OFF increments command position and ON decrements command position. 10: Pulse, Pulse decoding where FMB increments command position and FMA decrements command position. 11: Quadrature decoding of FMA and FMB with FMB leading FMA for incrementing command position. Quadrature decoding effectively multiplies the input frequency by 4 times. 12: Pulse and direction decoding where FMA is pulse train and FMB is direction. FMB ON increments command position and OFF decrements command position.
OUTPUT PULSE TYPE	UP-19	00~11	01	Sets the type of pulse output sequence and polarity of the PULSE OUTPUT. UP-20 must be set to xxxo for the PULSE OUTPUT to represent incremental actual position. 00: Pulse, Pulse encoding where APD pulses when the actual position increments and BPD pulses when the actual position decrements. 01: Quadrature encoding of APD and BPD with APD leading BPD for incrementing actual position. Each edge of the two pulse trains are counted as an output bit change. 10: Pulse, Pulse encoding where BPD pulses when the actual position increments and APD pulses when the actual position decrements.

4.1.4 USER PARAMETER MENU LOOP (cont'd)

USER PARAMETER	SYMBOL	SETTING RANGE	FACTORY SETTING	DESCRIPTION
OUTPUT PULSE TYPE (cont'd)	UP-19	00~11	01	11: Quadrature encoding of APD and BPD with BPD leading APD for incrementing actual position. Each edge of the two pulse trains is counted as an output bit change.
MONITOR OUTPUT FUNCTION	UP-25	000~111	010	Selects SPEED or TORQUE output and polarity of the MON test point. The first digit selects the MON output function. 0: TORQUE 1: SPEED The second digit selects the polarity of the MON output. 0: Normal 1: Invert
HOLDING BRAKE THRESHOLD	UP-28	0~100.0%	100%	When UP-16 is set to 0, UP-28 has no effect. When UP-16 is set to 1 or 2, the mechanical brake is applied when the motor speed falls below the value set in UP-28. The value in UP-28 is % of rated speed.
MOTOR TEST SPEED	UP-29	1~4000 r/min	50 RPM	The driver can be jogged manually by using the keypad. The jog speed is set with UP-29 in RPM.
EXTERNAL REGEN RESISTOR VALUE (Software version 10 and above)	UP-30	0~100.0 ohms	0.0 ohms	Value of the optional external regen resistor. When external regen resistor is used, the value of the resistor is entered to allow the driver to calculate average power into the regen resistor. When the internal regen is used, enter 0.0. See Section 9 for details on Regen Resistor selection. This parameter is used with DSD-35 and larger drivers.
EXTERNAL REGEN RESISTOR WATTAGE (Software version 10 and above)	UP-31	0~327.67 Kw	0.0 Kw	Power rating of the optional external regen resistor. When external regen resistor is used, the power rating in Kw of the resistor is entered to allow the driver to calculate average power into the regen resistor. When the internal regen is used, enter 0.0. See Section 9 for details on Regen Resistor selection. This parameter is used with DSD-35 and larger drivers.

4.1.5 HP PARAMETER MENU LOOP

The HP Parameter Menu Loop provides access to basic setup parameters that are less commonly used. Each parameter is displayed in two successive displays. The coded parameter name appears on the first display and the parameter value appears on the second display. The  key will always move from the parameter-coded name to the parameter value. The  key will always move from the parameter value to the coded parameter name.



Parameters can be read or written in the HP Parameter Menu Loop. The procedure to write into a parameter is found in [Section 4.2](#).

The HP Parameter Menu Loop is organized as follows:

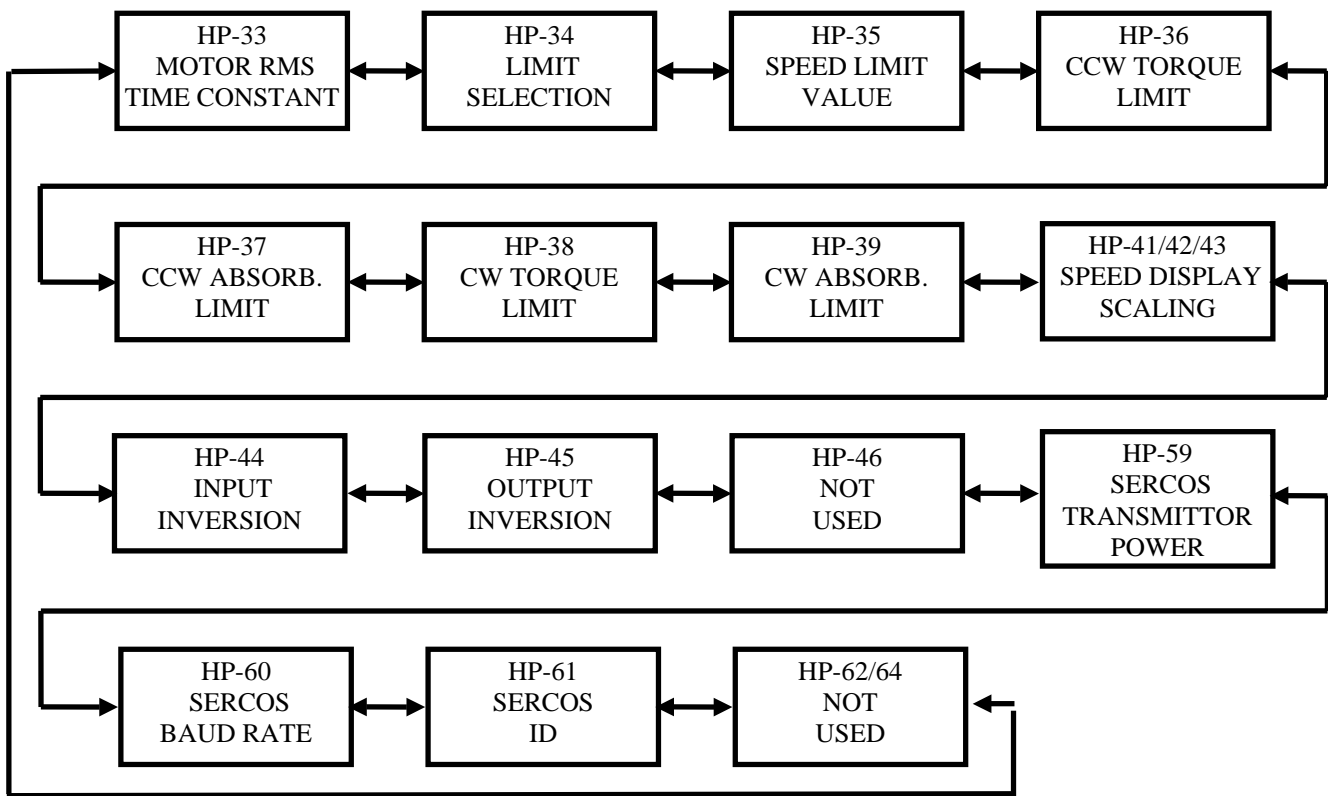

4.1.5 HP PARAMETER MENU LOOP (cont'd)

SETUP PARAMETER	SYMBOL	SETTING RANGE	FACTORY SETTING	DESCRIPTION
MOTOR RMS TORQUE TIME CONSTANT	HP-33	1~60 sec	30 sec	Sets the time constant for calculating motor rms torque that is displayed as parameter bL. Time constant should be set to approximately twice as long as the machine cycle.
TORQUE LIMIT SELECTION	HP-34	0~1	0	First digit is torque limit method: 0: Torque Limits Disabled. 1: Limit set by parameter UP-11 or HP-36 through HP-39 when UP-11 = 0.
CCW ROTATION TORQUE LIMIT	HP-36	0~100.0%	100%	Limits CCW rotation torque. 100% = Peak Torque See HP-34
CCW ROTATION ABSORPTION TORQUE LIMIT	HP-37	0~100.0%	100%	Limits CCW rotation absorption (braking) torque. 100% = Peak Torque See HP-34
CW ROTATION TORQUE LIMIT	HP-38	0~100.0%	100%	Limits CW rotation torque. 100% = Peak Torque See HP-34
CW ROTATION ABSORPTION TORQUE LIMIT	HP-39	0~100.0%	100%	Limits CW rotation absorption (braking) torque. 100% = Peak Torque See HP-34
SPEED DISPLAY ELECTRONIC RATIO NUMERATOR	HP-41	1~32767	1	Parameters HP-41/HP-42 form a fraction that is used to scale the scaled Motor Speed display "F". The motor speed is multiplied by the fraction, and then put on the display. This allows a speed display that is scaled to the speed of the actual machine rather than the speed of the motor. The scaling can also allow the driver to display speed in different
SPEED DISPLAY ELECTRONIC RATIO DENOMINATOR	HP-42	1~32767	1	Units such as in/sec rather than the default motor RPM. Scales the driver display and optional external display if used.
SPEED DISPLAY DECIMAL POINT POSITION	HP-43	0~7	0	HP-43 sets the position of the decimal point in the optional external speed display. 0: No decimal point 1: Least significant digit ... 7: Most significant digit
INPUT INVERSION	HP-44	000~1FF	000	This parameter forms a hexadecimal bit mask that inverts the input when the bit is set to 1 and does not invert the input when the bit is 0. The LSB is for IN0 and so on. (i.e. HP-44=8C inverts inputs IN7, IN3 & IN2)















4.1.5 HP PARAMETER MENU LOOP (cont'd)



SETUP PARAMETER	SYMBOL	SETTING RANGE	FACTORY SETTING	DESCRIPTION
OUTPUT INVERSION	HP-45	00~FF	00	This parameter forms a hexadecimal bit mask that inverts the output when the bit is set to 1 and does not invert the output when the bit is 0. The LSB is for OUT0 and so on. (i.e. HP-45=4A inverts outputs OUT6, OUT3 & OUT1)
SERCOS TRANSMITTER CONFIGURATION	HP-59	01-24	1	Sets the SERCOS Transmitter Power and mode of operation. First digit on the right defines the transmitter power. 1: High Power 2: Medium High Power 3: Medium Low Power 4: Low Power Second digit defines the mode of operation. 0: Normal Operation 1: Continuous Signal Light 2: Zero Bit Stream Power must be turned off and on for this parameter to take effect.
SERCOS BAUDRATE	HP-60	02, 04, 08, 10	02	Sets the SERCOS Communication Baudrate 02: 2 mbaud 04: 4 mbaud 08: 8 mbaud 10: 16 mbaud Power must be turned off and on for this parameter to take effect.
SERCOS DEVICE ID	HP-61	0-254	1	Sets the SERCOS Device Address on the SERCOS ring. If ID=0, then the device ignores commands and the drive acts as a repeater only. Power must be turned off and on for this parameter to take effect.

4.2 WRITING NEW VALUES IN READ/WRITE PARAMETERS

Many parameters require adjustment or modification to properly configure the Delta S driver. These parameters include AJ, UP and HP. The procedure for changing these parameters is the same and is described in this section. Although the parameter is changed in the display, pressing the  key is required to log the new parameter value in the driver's non-volatile memory.





To change a parameter:

- Navigate the main menu using the    keys to get the parameter name to be changed in the display. See [Figure 4.2](#).
- Press the  key to get the parameter value in the display.
- Concurrently press the  and  keys to prepare the parameter for change. The least significant digit in the display will now be flashing, indicating that the least significant digit can be increased or decreased with the   keys.
- Use the  key to move the flashing digit to the left to prepare another digit in the display for change. When the flashing digit reaches the left most position one more  key press will return the flashing digit to the right most position.
- Repeating the above steps, change the display to the new desired value.
- Press the  to log the new parameter setting in the Delta S driver's non-volatile memory.
- The    keys can again be used to navigate the main menu.

Changes in the AJ parameters take effect when the parameter is changed using the   keys. The UP and HP parameters require pressing the  key to have the parameter change take effect.

The parameter UP-02 requires a power OFF, power ON cycle to have the parameter take effect.

4.3 NAVIGATING THE SPECIAL FUNCTION MENU LOOP

The Special Function Menu Loop provides special diagnostic and setup functions. Enter the Special Function Menu by concurrently pressing the    keys for 5 seconds while the Main Menu status display shows motor speed [r 0]. The special menu will appear with the display showing [FrEE]. To exit the Special Function Menu double click the  key.

Once in the Special Menu the  key is used to move around the menu loop.



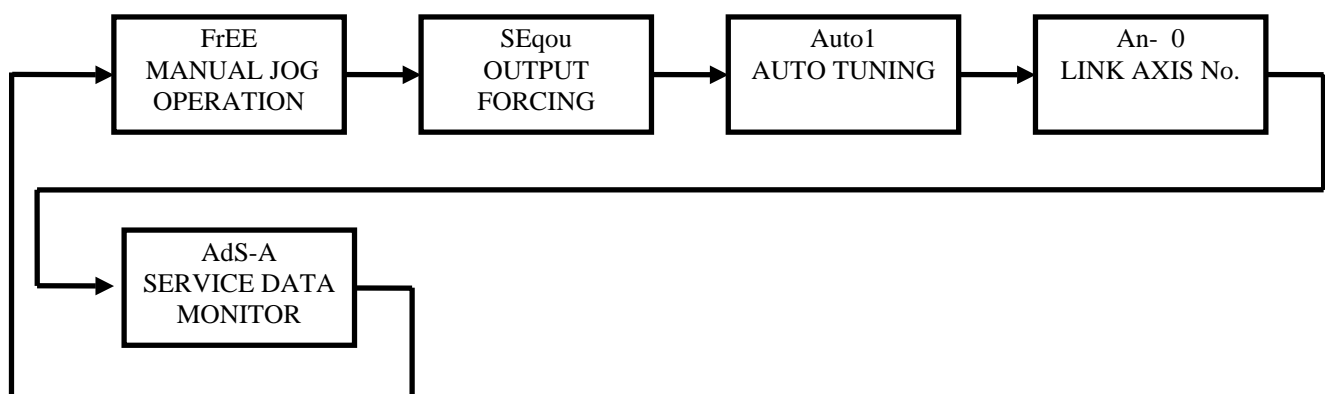







The Special Menu Loop is organized as follows:



4.3.1 MANUAL JOG OPERATION

The driver can be jogged manually using the front panel keyboard switches. The jog speed is set by UP-29 and the accel/decel rate is set by UP-12, UP-13 or UP-14. The normal brake sequencing of BRAKE OUTPUT and BRAKE CONFIRM must be observed during jog operation.

Caution should be used when manually jogging the motor. Be sure all personnel are clear of moving parts and that the motor's movement is not restricted by ancillary moving mechanisms.

- Use the  key to locate the FrEE menu display in the Special Menu.
- Activate the servo by pressing  key. The display shows the current jog speed [L 0]
- Jog the motor CCW using the  key or CW by using the  key. The motor continues to run as long as the key is held down.
- Pressing the   keys together latches the motor in jog CCW until the  or  key is momentarily pressed to unlatch the jog operation and stop the motor. The   keys provide similar latched jog operation in the CW direction.
- Deactivate the servo by pressing  key. The display returns to [FrEE].

4.3.2 OUTPUT FORCING FUNCTION

The Output Forcing Function is not valid with the Delta S Driver.

4.3.3 AUTO TUNING

The Delta S provides an automatic servo parameter tuning function. Auto Tuning is accessed via the Special Function Menu. **Section 8** of this manual is dedicated to auto and manual tuning of the driver parameters. See **Section 8** for Auto Tuning procedure.

4.3.4 LINK AXIS NUMBER

The Link Axis Number is not used with the Delta S Driver.

4.3.5 SERVICE DATA MONITOR

The Delta S Driver contains detailed service information. The Service Data Monitor contains detailed coded information meant for a qualified IIS Technician. There is no user serviceable information in this menu item. Contact IIS for any service related issues.

