

IB-11B032

MOTION CONTROL SYSTEMS, MSC SERIES

AUGUST 1998

# RFC-240X

## RESOLVER/FIBER OPTIC CONVERTER

### INSTRUCTION BOOK

INDUSTRIAL INDEXING SYSTEMS, Inc.

Revision - 0  
Approved By:

# TABLE OF CONTENTS

<b>I. INTRODUCTION</b> .....	<b>1</b>
<b>II. OPERATION</b> .....	<b>1</b>
<b>III. SPECIFICATIONS</b> .....	<b>2</b>
<b>IV. FUNCTIONAL TEST FOR RFC-240X</b> .....	<b>4</b>
<b>V. SETTING RESOLVER 0.0 SHAFT ANGLE</b> .....	<b>6</b>

# RFC-240X

## Resolver to Fiber-Optic Converter

### I. INTRODUCTION

The RFC-XXX (Resolver to Fiber-Optic Converter) is a DIN rail mounted assembly to be used with MSC-850, MSC-250, DeltaMax and DeltaPro Motion Control Systems. Power supplied to the RFC-240X is 24V DC. See Section III on specifications.

The RFC-240X is connected to a resolver with IIS cable part number C-200YYY (see [Figure 4](#)). Resolver operation is verified by Red LEDs labeled; MSB, LSB1, LSB0 (see [Figure 2](#)). There is a 16-position selector switch to select the resolver resolution (see [Table 1.1](#)). A Fiber Optic cable (see [Figure 5](#)), IIS part number C-966YYY (YYY is the cable length in feet), links the RFC-240X to an MCF-850, MSC-250, DeltaMax or DeltaPro.

### II. OPERATION

The RFC-240X takes resolver positional information and transmits this information serially through the C-966YYY fiber optic cable. Typically, only one fiber optic transmitter (U10) is present on the RFC-240X, but, depending on the application, up to eight fiber optic transmitters are available (see [Figure 2](#)). All of the fiber optic transmitters transfer the same data.

The X in the 240X part number selects the number of fiber optic transmitters. On power up, the transmission of data is delayed by 100ms. After this time, positional information is transmitted once per millisecond. The 16-position selector switch (see [Figure 2](#)) determines the resolver resolution according to the information in given in [Table 1.1](#).

### III. SPECIFICATIONS

#### A. Environment

Operating Temperature: 0 to 60°C  
Ventilation: Unit must have 5 inches of free airflow above  
Humidity: 30% to 90% relative (non-condensing)

#### B. Size

Length: 9.80 in. Max.  
Width: 3.20 in. Max.  
Height: 2.70 in. Ref.

#### C. Power Requirements For RFC-240X

Input Voltage: 24V dC  $\pm$  10%  
Input Current: 1 Amp Maximum

#### D. Resolver Type

Reference Signal: 2.6KHz @ 8V RMS  
Feedback Signals: 8V RMS Differential Input

#### E. Fiber Optic Link Cable

IIS Part No.: C-966YYY  
Max. Length: 100ft (30.5) Max.

**Table 1.1 - Configuration Switch and Code Bit Settings**

Configuration Switch Settings	Resolver Type				Controller Type
	Resolution (Bit)	Bits per Revolution	MAX Resolver Shaft Speed (RPM)	Description	
0	12	4096	3600	12 Bit Mode	MSC
1	14	16384	900	14 Bit Mode	MSC
2	16	65536	225	16 Bit Mode	MSC
3*	12	4096	N/A	Test Mode 100 CW	MSC
4*	12	4096	N/A	Test Mode 1000 CW	MSC
5*	12	4096	N/A	Test Mode 100 CCW	MSC
6*	12	4096	N/A	Test Mode 1000 CCW	MSC
7	10	1024	14400	10 Bit Mode	DELTAMAX
8	12	4096	3600	12 Bit Mode	DELTAMAX
9	14	16384	900	14 Bit Mode	DELTAMAX
A	16	65536	225	16 Bit Mode	DELTAMAX
B*	12	4096	N/A	Test Mode 100 CW	DELTAMAX
C*	12	4096	N/A	Test Mode 1000 CW	DELTAMAX
D*	12	4096	N/A	Test Mode 100 CCW	DELTAMAX
E*	12	4096	N/A	Test Mode 1000 CCW	DELTAMAX
F	10	1024	14400	10 Bit Mode	MSC

\* Test Modes which simulate a resolver turning at the noted speed and direction to simulate Master Resolver Motion or Trouble Shooting.

## IV. FUNCTIONAL TEST FOR RFC-240X

1. For the RFC-240X, set a Multimeter to a scale to read 24V DC.
2. Turn on the system power.
3. For the RFC-240X, verify 24V DC  $\pm$  10% from P2-1 to P2-2.
4. If the voltage is within specification, then continue with the next step. If the voltage is out of specification, then correct the voltage supply before proceeding.
5. Set a multimeter to the 10V AC scale.
6. Connect the meter leads to P1-7 and P1-8 (white and black wires of C-200YYY cable, (see **Figure 3**).
7. The meter should indicate 8V AC  $\pm$  1V AC.
8. If an out of specification reading is obtained, remove P1 from the controller and connect the meter's leads to **ROHI** and **GND** test points on the RFC-240X.
9. The meter should indicate 8V AC  $\pm$  1V AC.
10. If an out of specification reading is still obtained, replace the RFC-240X. If readings are correct, then go on to the next step
11. With the 9-pin connector P1 connected to the RFC-240X, connect the meter leads to P1-1 and P1-2 (see **Figure 3**).
12. While observing the meter, rotate the motor shaft one full revolution. The voltage should rise to 8V AC  $\pm$  2V AC and fall to less than 1V AC twice per revolution.
13. With P1 connected to the RFC-240X connect the meter leads to P1-4 and P1-5 (see **Figure 3**).
14. While observing the meter, rotate the motor shaft one full revolution. The voltage should rise to 8V AC  $\pm$  2V AC and fall to less than 1V AC twice per revolution.
15. If an out of specification reading is obtained, go on to the next step. If the readings are correct, then go to Step 17.
16. Turn off power to the system.
17. Remove 9-pin connector P2 from the RFC-240X.
18. Set the multimeter to measure ohms (W).
19. Measure ohms (W) from connector P2-1 to P2-2. The reading should be between 20W and 300W.

#### IV. FUNCTIONAL TEST FOR RFC-240X (Cont'd)

20. Measure ohms (W) from connector P2-4 to P2-5. The reading should be between 20W and 300W.
21. Measure ohms (W) from connector P2-7 to P2-8. The reading should be between 20W and 300W.
22. Measure P2-1 thru P2-9 to earth ground (panel). None of the P2-X connections should have less than 10KW
23. Measure P2-1 to all other pins in the P2 connector. All readings should be greater than 10KW.
24. Measure P2-4 to all other pins in the P2 connector. All readings should be greater than 10KW.
25. Measure P2-7 to all other pins in the P2 connector. All readings should be greater than 10KW.
26. If there are any problems with steps 19 thru 25, then thoroughly ring out the resolver cable C-200YYY (see **Figure 5**) for continuity, shorts, and opens. If no problems are found with the cable, then replace the resolver.
27. Turn the system power ON. Then disconnect the Fiber Optic Cable from the Fiber Optic Transmitter on the RFC-240X.
28. Verify a red glow emanating from the Fiber Optic Transmitter.
29. If there is no glow, then replace the RFC-240X. If a red glow is present, go on to the next step.
30. Reconnect the Fiber Optic Cable to the Fiber Optic Transmitter on the RFC-240X.
31. Disconnect the opposite end of the Fiber Optic Cable from the motion controller.
32. Verify a red glow emanating from the end of the Fiber Optic Cable.
33. If there is no glow, then replace the Fiber Optic Cable. If a red glow is present, go to the next step.
34. Slowly rotate the resolver shaft. The LSB0 and LSB1 LEDs on the RFC-240X should toggle on and off with slow rotations of the shaft (see **Figure 1**). The MSB LED should be on for 180° of shaft rotation, and off for 180° of shaft rotation.

## IV. FUNCTIONAL TEST FOR RFC-240X (Cont'd)

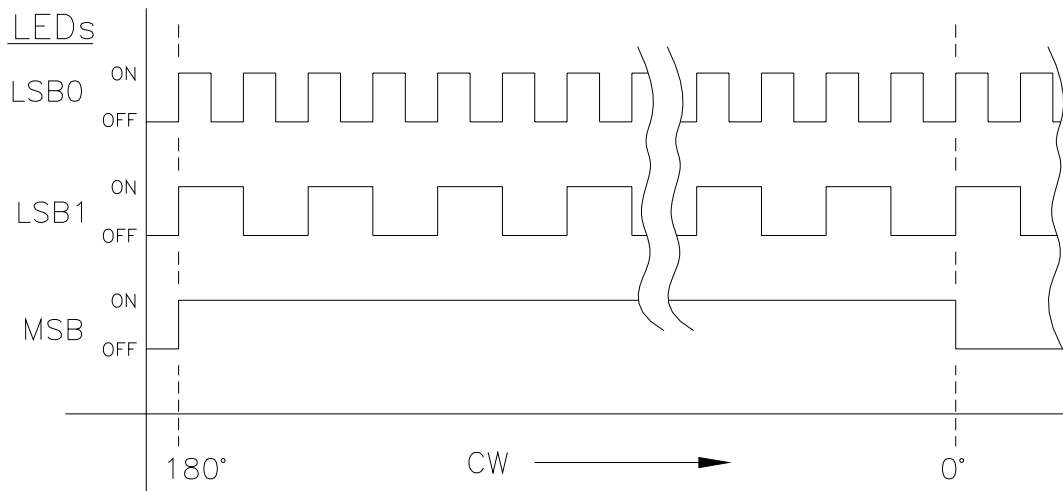
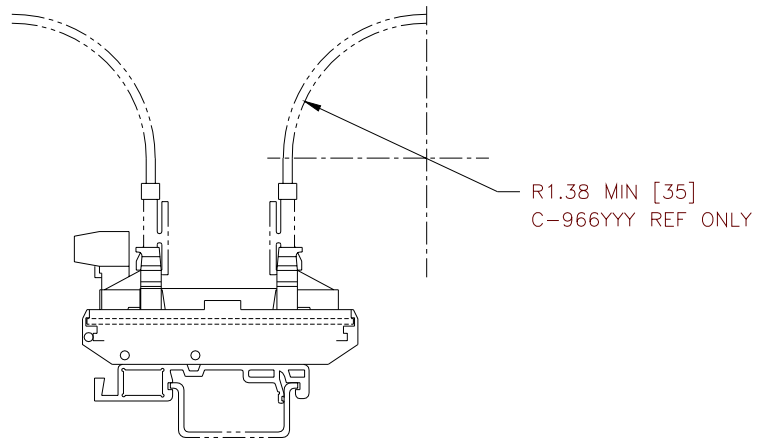
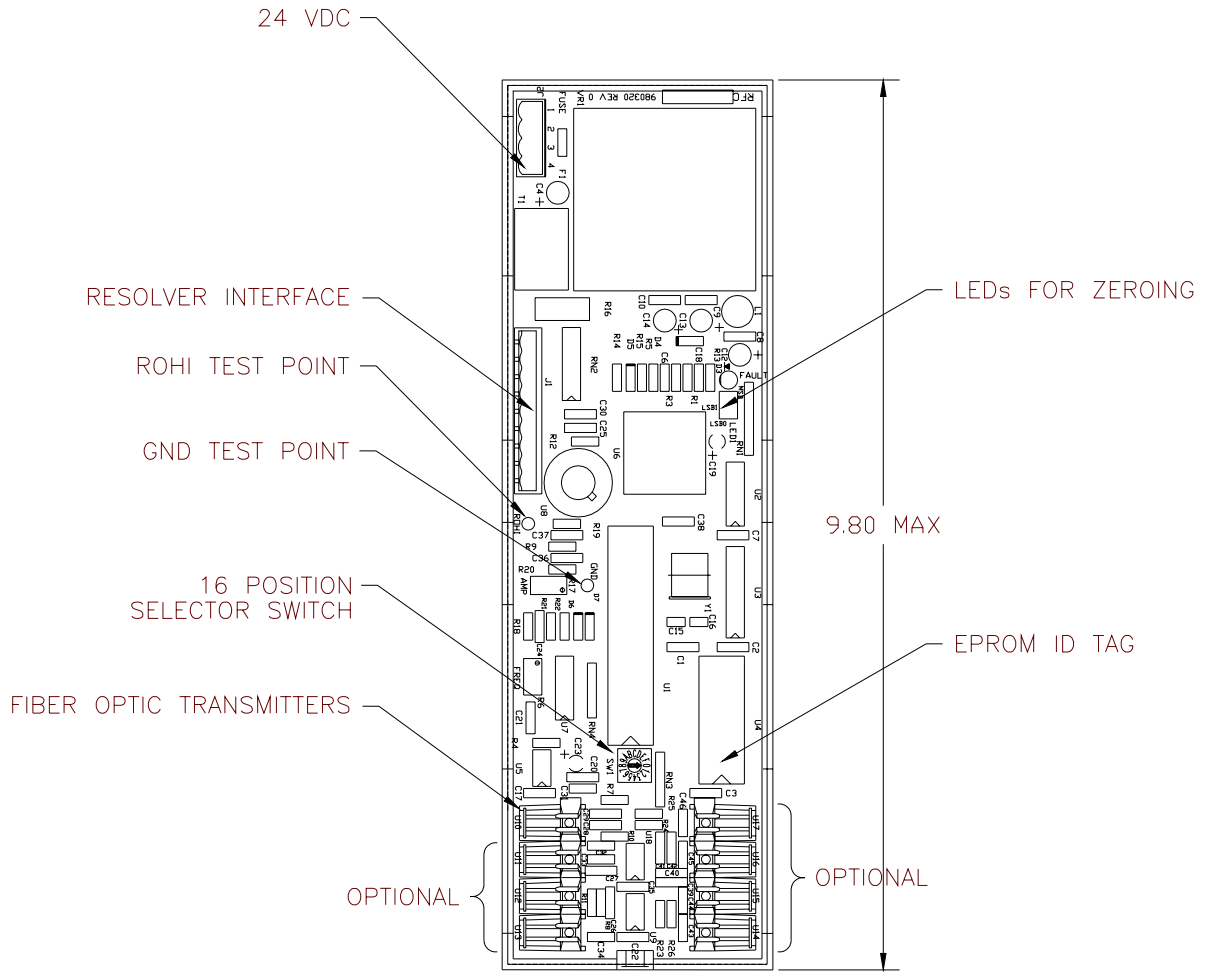

**Figure 1 - LED Table**

35. If the LEDs are not working properly, then replace the RFC-240X.
36. If the LED tests are good, then any other problems that occur may be from the Fiber Optic Receiver end of the Motion Controller, or the Motion Control software.

## V. SETTING RESOLVER 0.0 SHAFT ANGLE

1. Slowly rotate the resolver shaft CW while observing the LSB0, LSB1, and MSB LEDs on the RFC-240X.
2. Continue to rotate the shaft CW until the MSB LED is turned from ON to OFF (see **Figure 1**). At the toggling point of the MSB LED, the resolver is at 0.0 shaft angle.



**Figure 2 - RFC-240X Layout**

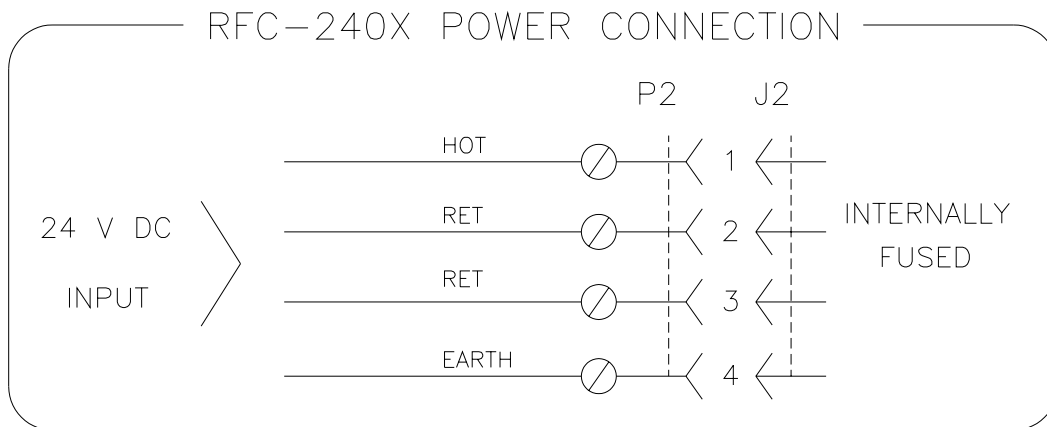
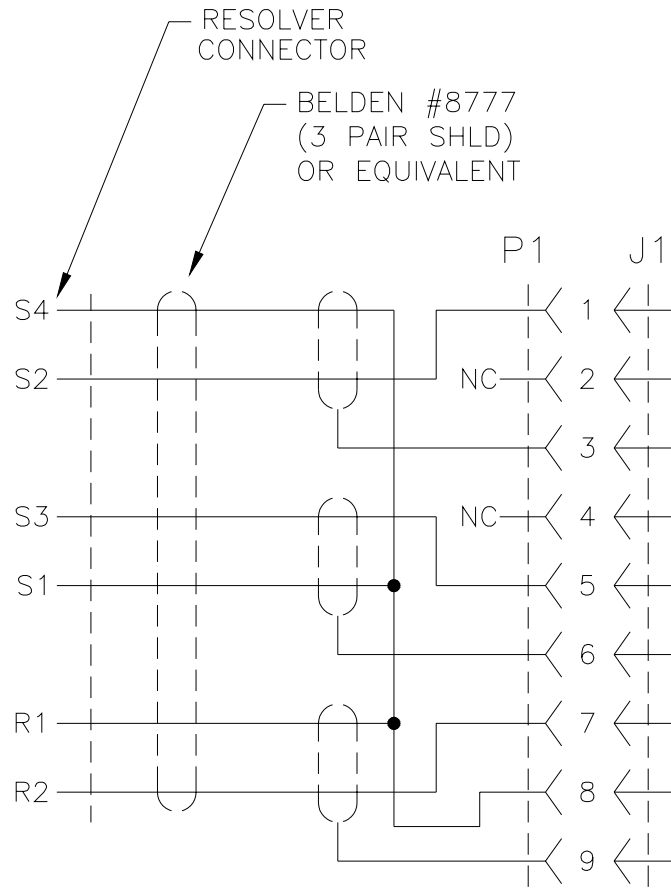

**Figure 3 - Connection Interconnection**

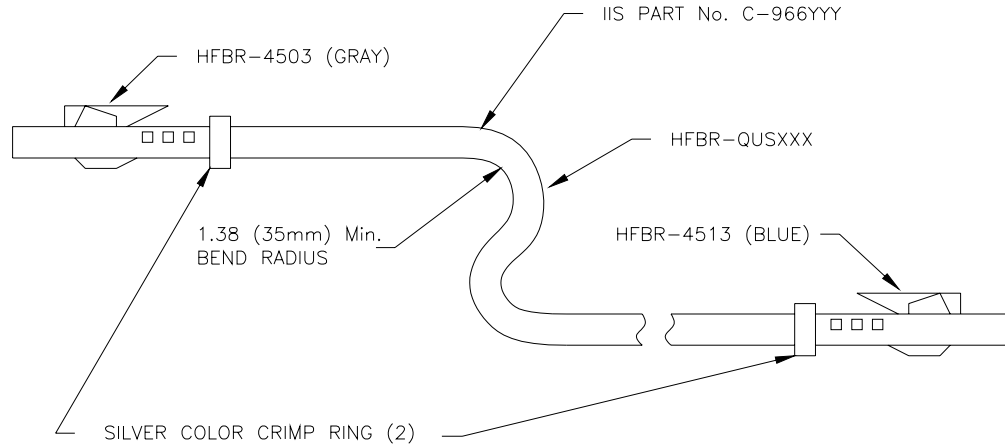

PREMADE CABLES

HEWLETT-PACKARD PART No.	LENGTH (METERS)	IIS PART No.	LENGTH (FEET)
HFBR-QLS001	1	C-966003	3
HFBR-QLS005	5	C-966015	15
HFBR-QLS010	10	C-966030	30
HFBR-QLS020	20	C-966060	60

NOTE: CABLE LENGTH NOT TO EXCEED 100 FT (30M)

**Figure 4 - Fiber Optic Link Cable, C-966YYY**

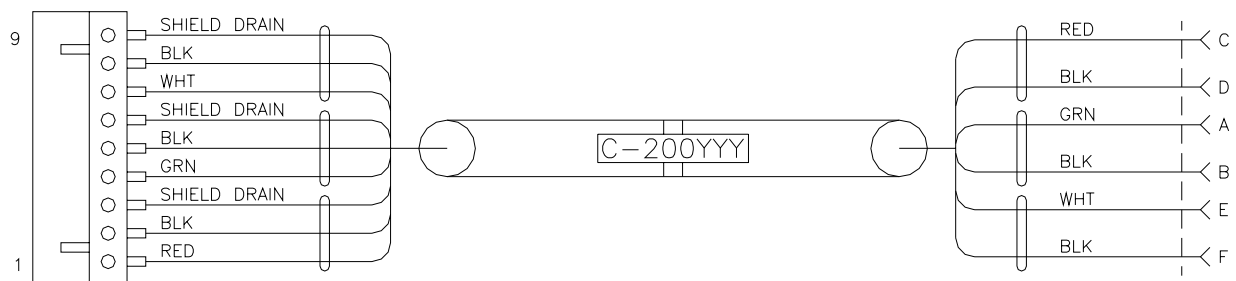

**Figure 5 - C-200YYY Cable**



IB-11B032



**INDUSTRIAL  
INDEXING SYSTEMS  
INC.**

**626 FISHERS RUN  
VICTOR, NEW YORK 14564**

**(585) 924-9181  
FAX (585) 924-2169**

PRINTED IN USA  
© 1998