

## SECTION 8 - DYNAMIC BRAKES

The Delta driver is equipped with special circuitry and software to sequence a dynamic braking relay connected across the motor windings. It is very important for proper operation that the dynamic braking relay contacts be open before the driver circuitry is turned on and that the driver is off before the dynamic braking relay contacts close. The driver in conjunction with external braking relays provide the proper sequencing to prevent driver damage.

If dynamic braking is not used, tie the BRAKE CONFIRM input ON for the DSD-1.5 through DSD-17.5 driver sizes. For DSD-35 and larger drivers, a jumper must be provided between B11 and B12. A B11 to B12 jumper is installed by the factory and must be removed if dynamic braking is to be used.

Parameter UP-16 should be set to the default value of 0 for dynamic braking or no brake connections.

Be sure to select a dynamic braking resistor with a sufficient peak power rating.

$$\text{Resistor Peak Power} = \frac{150 * V^2}{R}$$

Where V = maximum motor voltage when dynamic braking is applied.

General rule:  $V = 300 * (\text{motor speed @ braking}) / (\text{motor maximum speed rating})$

**Figures 8.1 and 8.2** show the connections for dynamic braking.

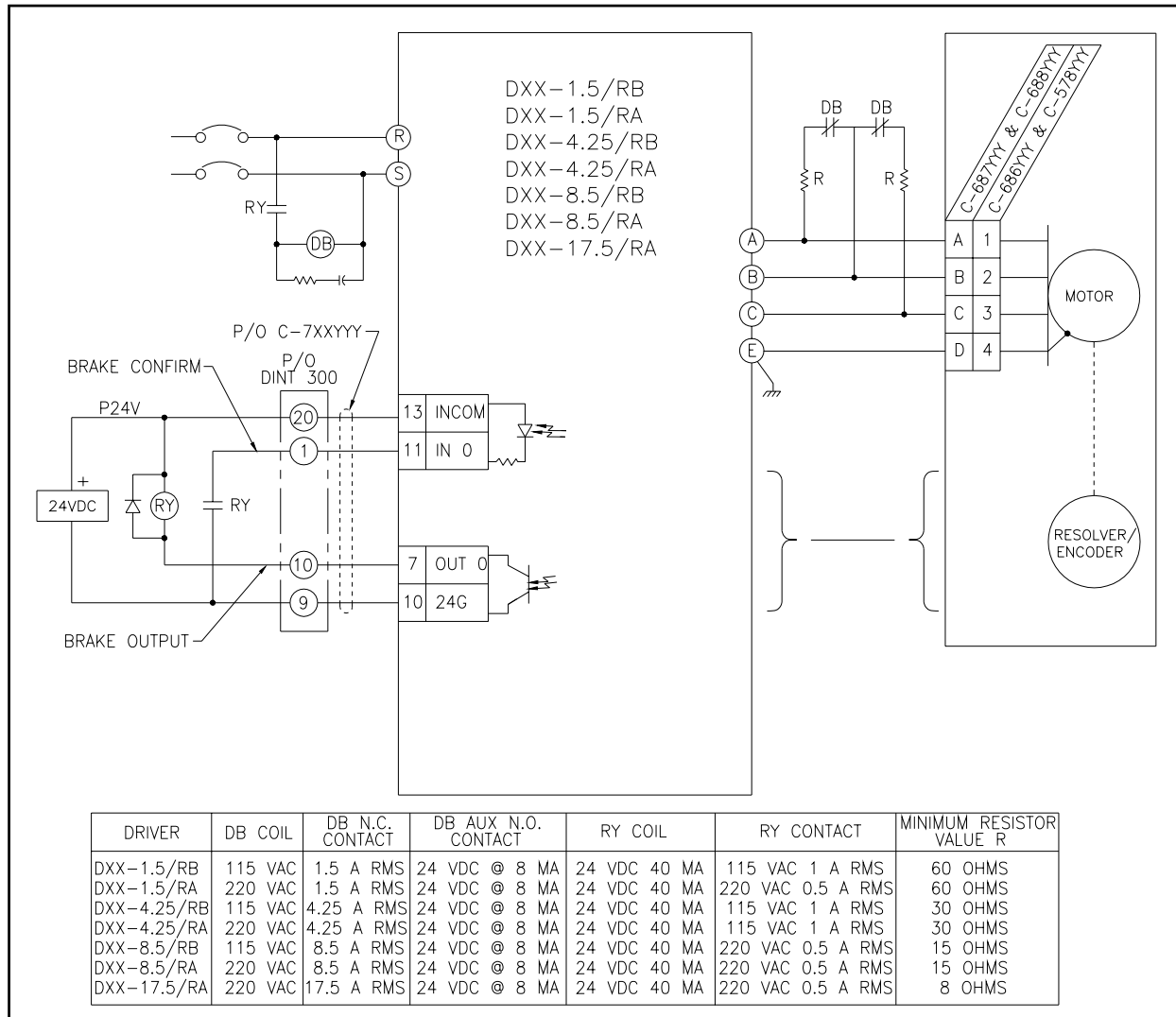

**Figure 8.1 - Dynamic Brake Connection for the DSD-1.5 Through DSD-17.5 Drivers**

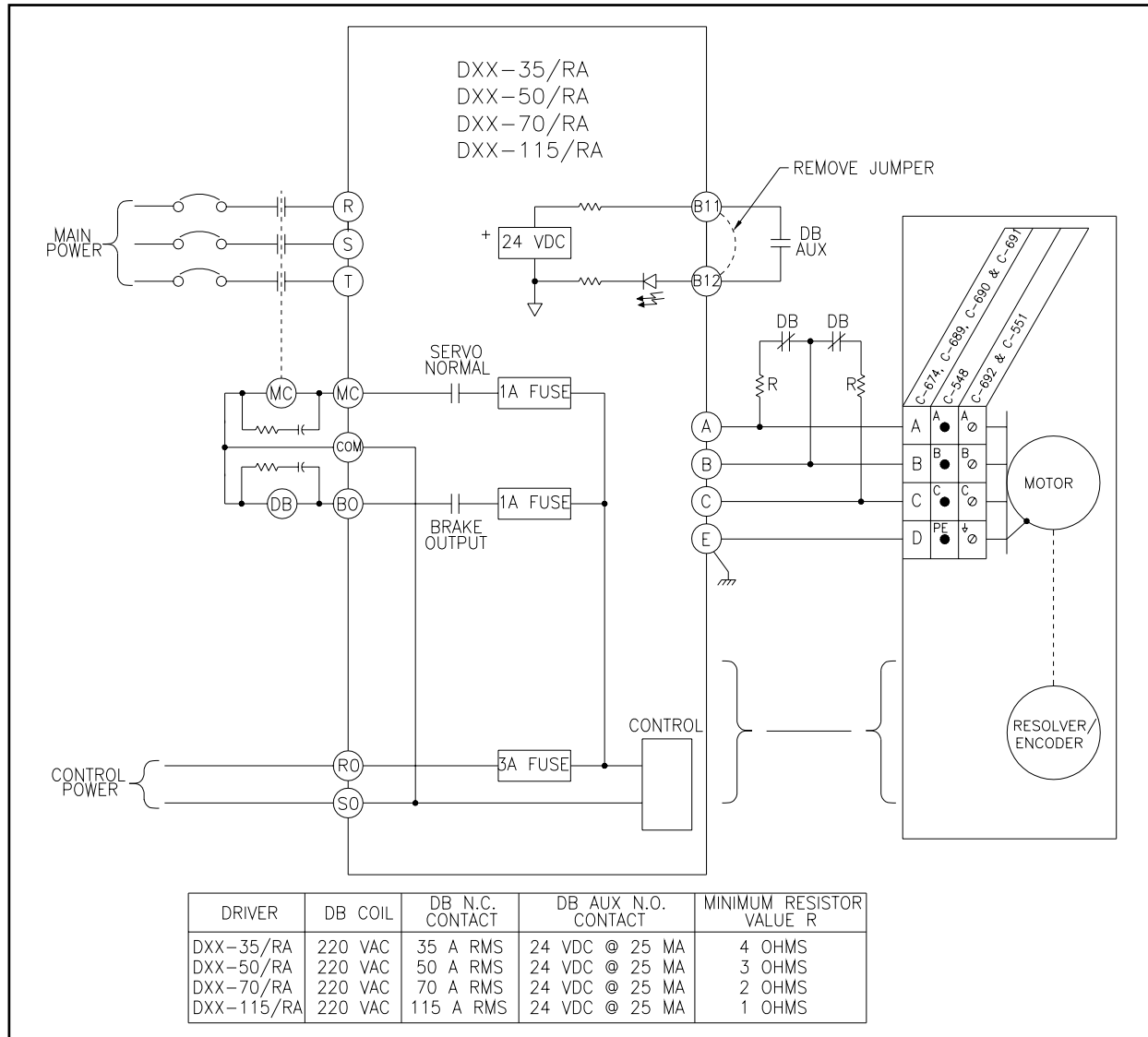
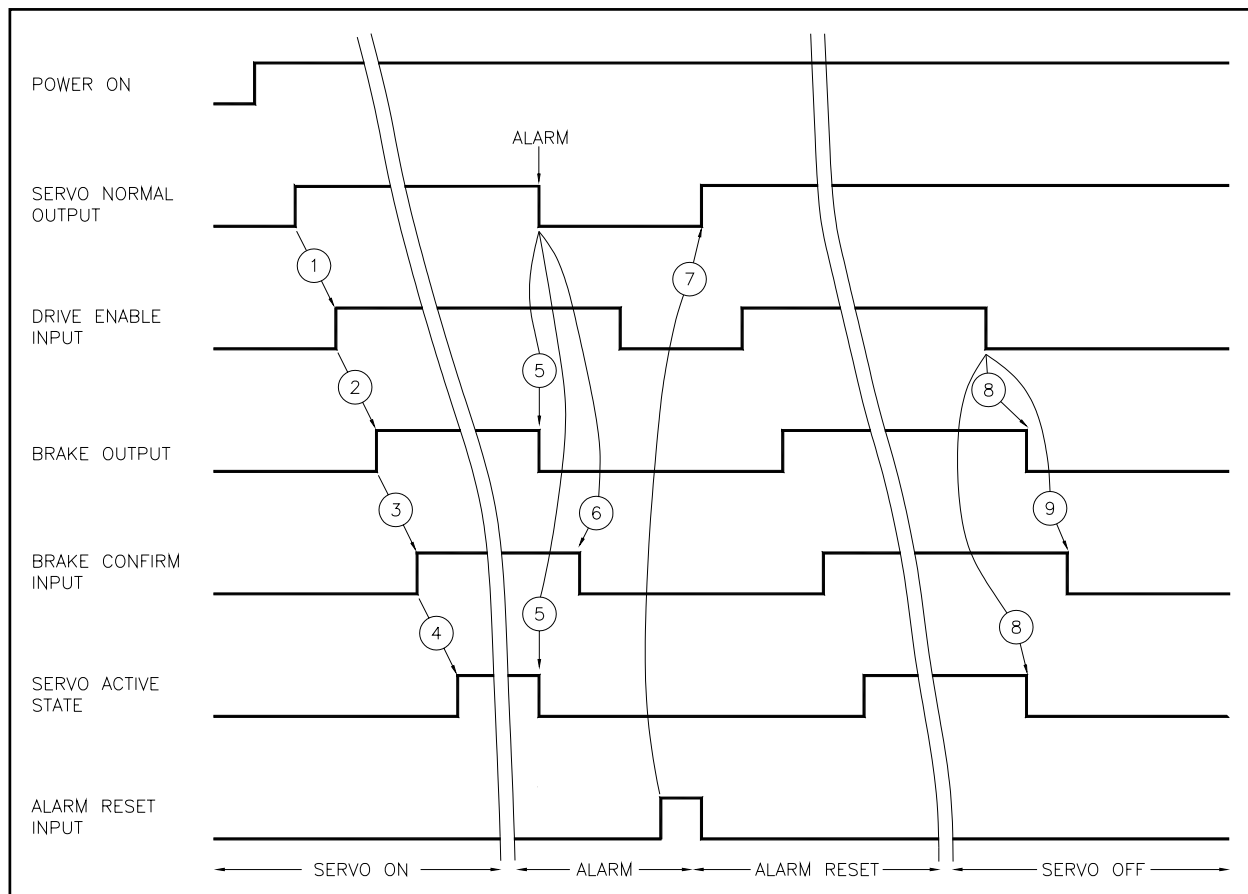

Figure 8.2 - Dynamic Brake Connection for the DSD-35 Through DSD-115 Drivers



**Figure 8.3 - Dynamic Braking Control Signals**

1. DRIVE ENABLE may be turned ON within 0.6 seconds of SERVO NORMAL.
2. BRAKE turns on within 800usec. of DRIVE ENABLE.
3. BRAKE CONFIRM must be returned within 100ms. or AL-14 will be generated.
4. The servo will become active within 800usec of sensing BRAKE CONFIRM.
5. When an alarm is sensed, the SERVO NORMAL and BRAKE outputs are turned OFF. The DRIVE ENABLE must be turned OFF before alarm clearing can be accomplished.
6. The BRAKE CONFIRM turns OFF indicating the braking relay has toggled and dynamic braking is engaged.
7. ALARM RESET causes driver to check for clearing of the alarm condition and if all alarm states are clear the SERVO NORMAL will turn ON within 30 ms. ALARM RESET should be turned OFF before DRIVE ENABLE is turned ON.
8. The servo becomes inactive and the BRAKE output turns OFF within 800usec of DRIVE ENABLE being turned OFF.
9. The BRAKE CONFIRM turns OFF indicating the braking relay has toggled and dynamic braking is engaged.