

SECTION 9 - REGEN RESISTOR SELECTION

9.1 DRIVER REGENERATION CAPACITIES

The Delta motor and driver have the ability to act as a brake for a rotating load. This condition typically occurs during the deceleration of the load or when the system is stopping a vertical load such as an elevator or lift. In both cases, the driver may have to absorb the mechanical and potential energy in the system. The driver must absorb the energy if the energy in the load exceeds to mechanical losses in the system.

The driver has 3 ways to absorb the energy from the load.

- Store the energy by charging the internal main DC bus capacitors (E_C)
- Use the energy internally to power the driver control circuitry (P_D)
- Dissipate the energy using a regeneration resistor (P_R)

The Delta S driver energy absorption capacities are as shown in [Table 9.1](#).

| DRIVER SIZE | INTERNAL REGEN CAPACITY (P_R) | INTERNAL POWER CONSUMPTION (P_D) | CHARGING CAPACITY (E_C) |
|-------------|-----------------------------------|--------------------------------------|-----------------------------|
| DS-1.5/RB | 0 W | 13 | 17 |
| DS-1.5/RA | 0 W | 13 | 17 |
| DS-4.25/RB | 0 W | 13 | 17 |
| DS-4.25/RA | 0 W | 13 | 17 |
| DS-8.5/RA | 0 W | 24 | 17 |
| DS-8.5/RB | 0 W | 17 | 17 |
| DS-17.5/RA | 0 W | 37 | 22 |
| DS-35/RA | 80 W | 80 | 38 |
| DS-50/RA | 80 W | 100 | 54 |
| DS-70/RA | 100 W | 200 | 94 |
| DS-115/RA | 180 W | 300 | 188 |

Table 9.1 - Energy Absorption Capabilities

The Delta S drivers are equipped with internal circuitry to detect a rise in the main DC power bus indicating energy absorption. If the DC power bus reaches approximately 400 VDC, the regeneration circuit is turned on to prevent the main DC power bus from rising to 420 VDC which will result in an over voltage alarm AL-02.

9.2 SELECTION OF REGENERATION RESISTOR

The amount of energy stored in the moving components of the system must be calculated and compared to the energy absorption capacity of the driver to determine if an external regeneration resistor is required.

9.2 SELECTION OF REGENERATION RESISTOR (cont'd)

The stored energy is of two basic types, kinetic energy in the form of a moving mass and potential energy of a mass being held against gravity.

$$E_k = 0.5 * (J_M + J_L) * (2 * \pi * N / 60)^2$$

$$E_P = (2 * \pi * N * T_g * t_b / 60)$$

Calculate the system losses in the motor, driver and friction.

$$E_L = (P_M + P_D + (\pi * N * T_f / 60)) * t_a$$

Calculate the regeneration power.

$$P_R = (E_k + E_P - E_L - E_C) / t_c$$

If regeneration power P_R is greater than 0.0, a regeneration resistor will be needed to prevent the main DC power bus from generating an over voltage alarm AL-02.

Where:

- E_k = Net kinetic energy Joules
 - E_P = Net Potential energy Joules
 - E_L = Energy loss due to friction Joules
 - E_C = Driver charging capacity Joules (See [Table 9.1](#))
 - J_M = Motor rotor inertia $kg\cdot m^2$
 - J_L = Load inertia $kg\cdot m^2$
 - N = Motor speed in RPM
 - P_M = Motor loss watts (10% of motor rating)
 - P_D = Driver internal power consumption watts (See [Table 9.1](#))
 - T_f = System friction torque N-m
 - T_g = Net torque to hold up load against gravity N-m
 - P_R = Regen power watts (See [Table 9.1](#))
 - t_a = Deceleration time
 - t_b = Move time
 - t_c = Cycle time
-] See [Figure 9.1](#)

* The above equations are reasonable approximations.

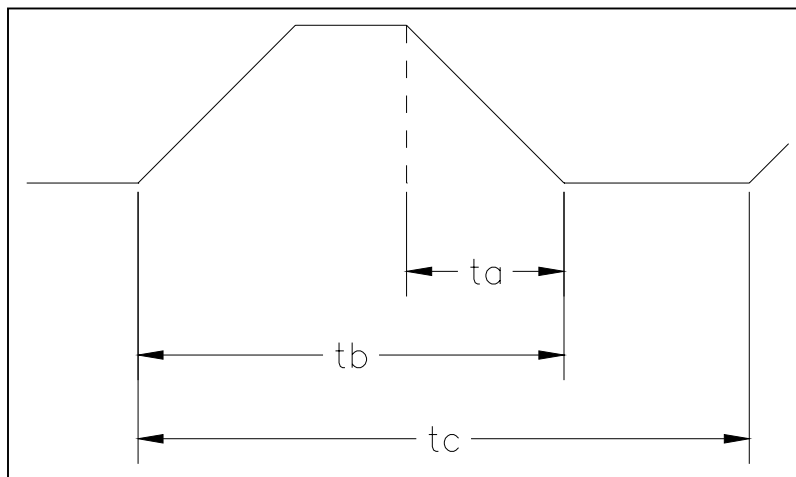

Figure 9.1

9.2 SELECTION OF REGENERATION RESISTOR (cont'd)

Drivers DS-1.5 through DS-17.5 do not contain an internal regeneration resistor. If a regeneration resistor is required, an external resistor with a power rating of at least P_R watts must be connected.

Drivers DS-35 through DS-115 contain internal regeneration resistors. If the internal regeneration resistor capacity is greater than P_R watts, no external resistor is needed. If the internal resistor is not large enough, an external resistor with a power rating of at least P_R watts must be connected. If an external regeneration resistor is needed, parameters UP-30 and UP-31 must be set to the values of the external resistor.

Table 9.2 External resistor specifications.

| DRIVER SIZE | RESISTANCE | MAX WATTAGE | WIRE GAUGE |
|-------------|--------------|-------------|-----------------------------|
| DS-1.5/RA | 30~100 Ohms | 300 W | 14 AWG 1.25 mm ² |
| DS-1.5/RB | 30~100 Ohms | 300 W | 14 AWG 1.25 mm ² |
| DS-4.25/RA | 30~100 Ohms | 300 W | 14 AWG 1.25 mm ² |
| DS-4.25/RB | 30~100 Ohms | 300 W | 14 AWG 1.25 mm ² |
| DS-8.5/RA | 30~100 Ohms | 300 W | 14 AWG 1.25 mm ² |
| DS-8.5/RB | 30~100 Ohms | 300 W | 14 AWG 1.25 mm ² |
| DS-17.5/RA | 30~70 Ohms | 400 W | 14 AWG 1.25 mm ² |
| DS-35/RA | 12.5~25 Ohms | 2.4 KW | 12 AWG 3.5 mm ² |
| DS-50/RA | 12.5~25 Ohms | 3 KW | 12 AWG 3.5 mm ² |
| DS-70/RA | 10~15 Ohms | 5.5 KW | 10 AWG 5.5 mm ² |
| DS-115/RA | 6~15 Ohms | 11 KW | 8 AWG 16 mm ² |

Table 9.2 - External Resistor Specifications

Figures 9.2 and 9.3 shows how to connect an external regeneration resistor to the Delta S drivers.

9.2 SELECTION OF REGENERATION RESISTOR (cont'd)

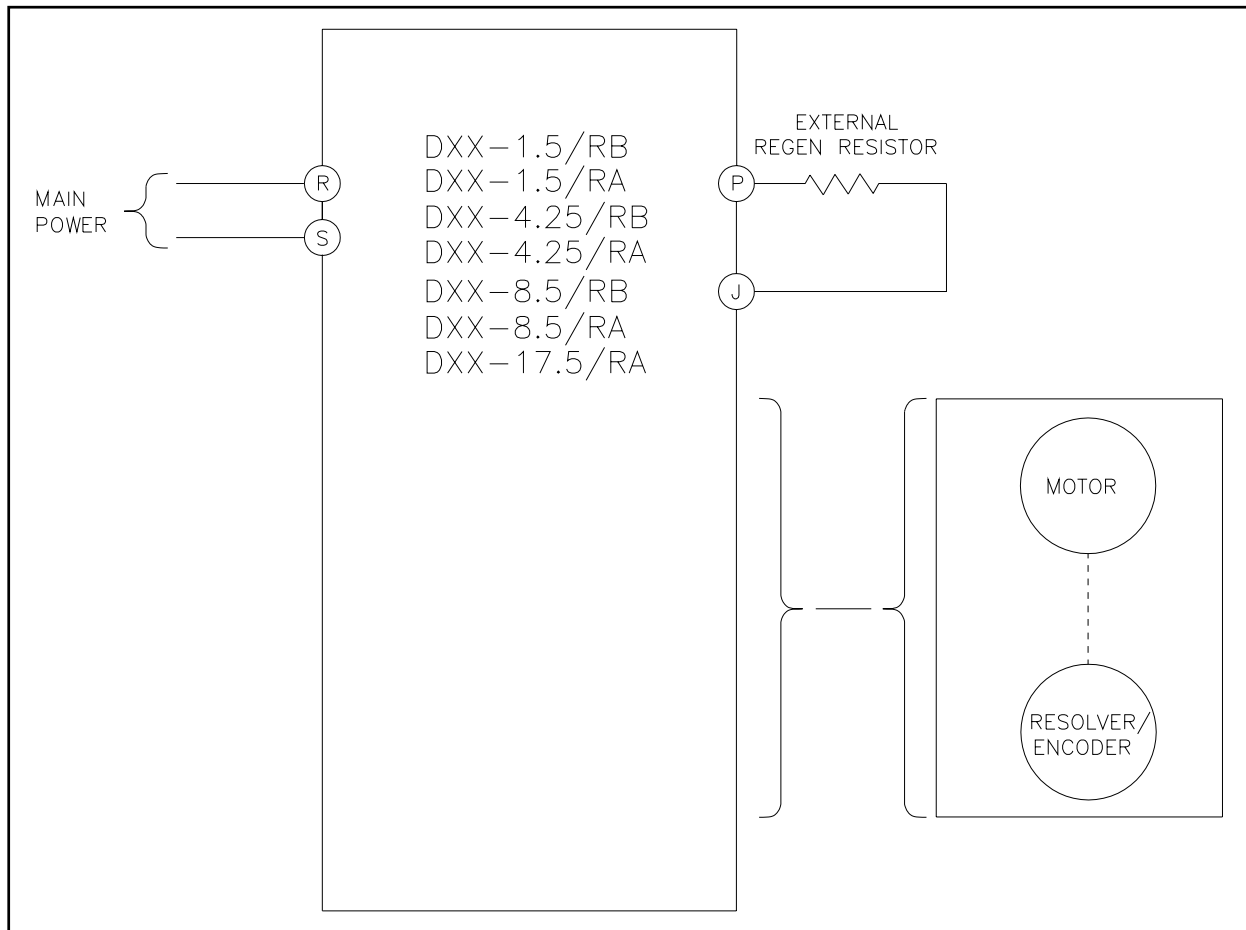

Figure 9.2 - Connection of an External Regen Resistor for Driver Sizes DS-1.5 Through DS-17.5

9.2 SELECTION OF REGENERATION RESISTOR (cont'd)

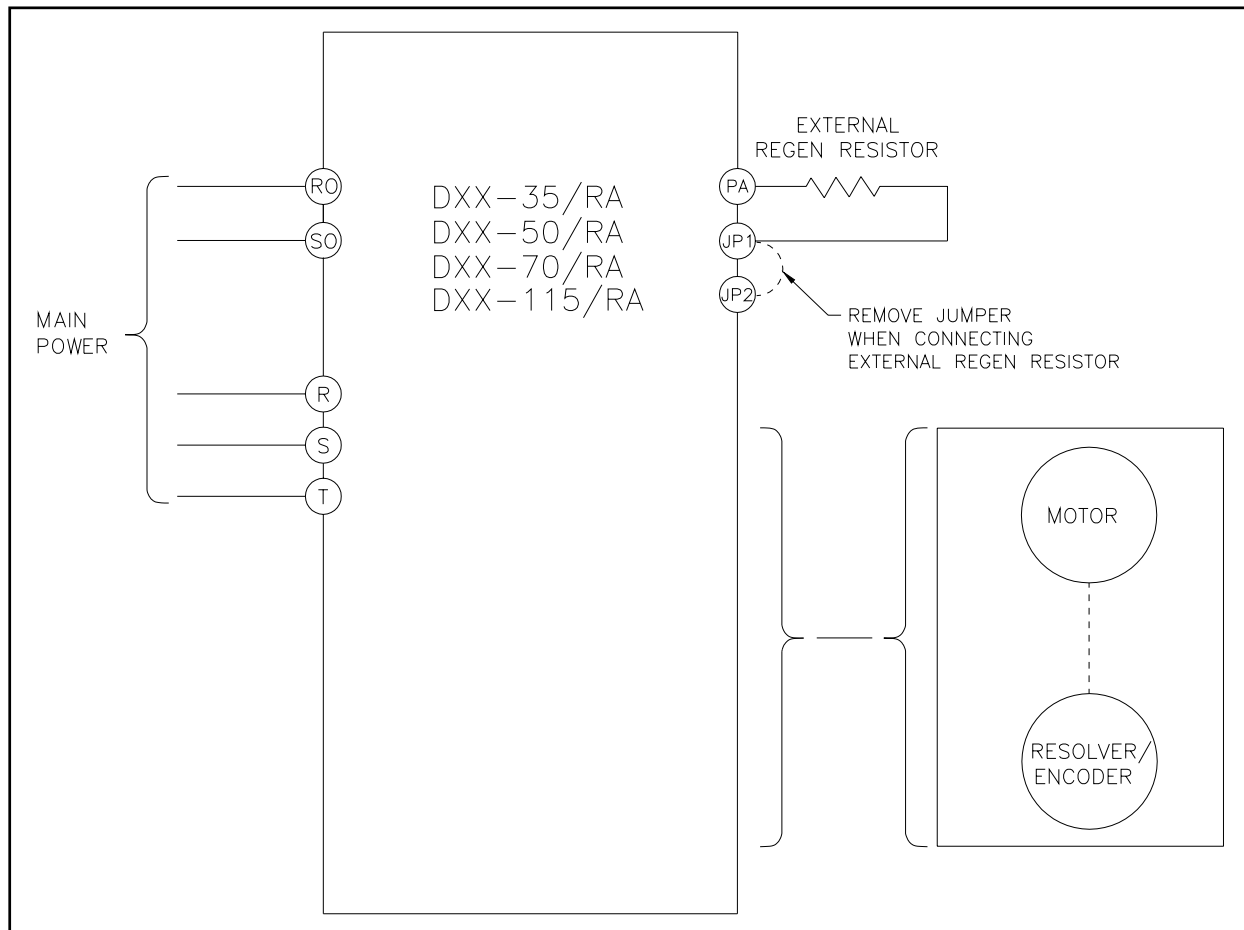

Figure 9.3 - Connection of an External Regen Resistor for Driver Sizes DS-35 and Larger

The regeneration resistor is subjected to severe peak power loads during regeneration. The driver switches the regeneration resistor across the DC power bus using PWM techniques to regulate the DC power bus voltage during regeneration dumping. When the driver's switch is on the regeneration resistor is subjected to the following peak power:

$$\text{PEAK POWER} = (400 \text{ VDC})^2 / \text{RESISTOR VALUE in ohms}$$

Be sure to select a regeneration resistor that can sustain the required peak power and continuous power ratings.

9.3 STANDARD REGENERATION RESISTOR PACKAGES

In general, wound metal ribbon resistors are recommended for this type of application. IIS offers a complete line of enclosed panel mounted regen resistor units to complement the Delta S driver. Various combinations of series and parallel connections are allowed to provide adequate regen resistor capacity.

| IIS P/N | Description |
|-----------------|----------------------|
| MFS30A300J* | 30 Ohm 30 Watts |
| RGH200-30* | 30 Ohm 200 Watts |
| DRGN-20/400* | 20 Ohm 400 Watts |
| DRGN-45/420 | 45 Ohm 420 Watts |
| DRGN-22.5/655 | 22.5 Ohm 655 Watts |
| DRGN-15/880 | 15 Ohm 880 Watts |
| DRGN-11.25/1120 | 11.25 Ohm 1120 Watts |

*Not UL/CE approved

EXAMPLE CALCULATION:

If 4 KW of regen were needed on a DSD-115 driver, four (4) DRGN-11.25/1120 units could be connected as follows to yield 11.25 Ohms at 4480 Watts.

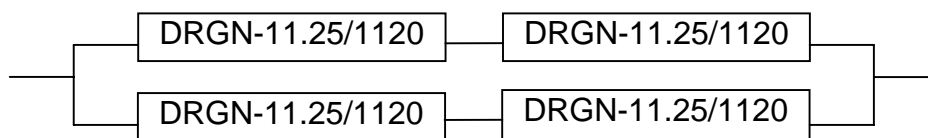

DRAWING NUMBER

MFS30A300J
 RGH200-30
 DRGN-20/400
 DRGN-45/420
 DRGN-45/420-2
 DRGN-22.5/655
 DRGN-15/880
 DRGN-11.25/1120

DESCRIPTION

Resistor
 Regen Resistor
 Regen Resistor
 Regen Resistor
 Regen Resistor
 Regen Resistor
 Regen Resistor
 Regen Resistor

NOTES:

- 1.) THIS RESISTOR IS NOT UL OR CE APPROVED.
- 2.) RESISTOR MUST BE SECURELY MOUNTED ON LARGE HEATSINK SUCH AS ENCLOSURE WALL OR BACKPANEL.

| SPECIFICATIONS | |
|------------------------|----------|
| RESISTANCE: | 30 Ohms |
| CONTINUOUS POWER: | 30 Watts |
| MAXIMUM VOLTAGE: | VDC |
| MAXIMUM PULSE CURRENT: | 15 A |
| MAXIMUM RMS CURRENT: | 1 A |
| DUTY CYCLE | 6 % |

DRILL $\phi 0.13$ HOLE ON MOUNTING
 PANEL APPROX. WHERE SHOWN
 FOR PIN

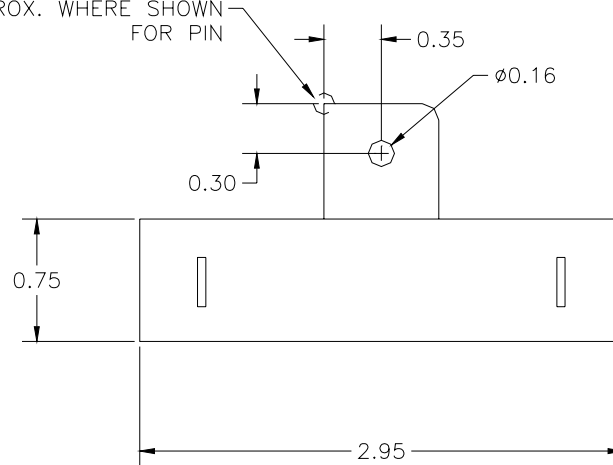

INDUSTRIAL INDEXING SYSTEMS, Inc.

www.iis-servo.com

TITLE
 RESISTOR, 30 OHM, 30W

DRAWING NUMBER
 MFS30A300J

NOTES:

- 1) RESISTOR MUST BE MOUNTED ON A FLAT SURFACE AT LEAST 12" X 12" IN FREE AIR TO MEET THE 200 WATT POWER RATES.
- 2) THIS RESISTOR IS NOT UL OR CE APPROVED.

SPECIFICATIONS

| | |
|------------------------|-----------|
| RESISTANCE: | 30 Ohms |
| CONTINUOUS POWER: | 200 Watts |
| MAXIMUM VOLTAGE: | 425 VDC |
| MAXIMUM PULSE CURRENT: | 14.0 A |
| MAXIMUM RMS CURRENT: | 5.0 A |
| DUTY CYCLE | 50% |

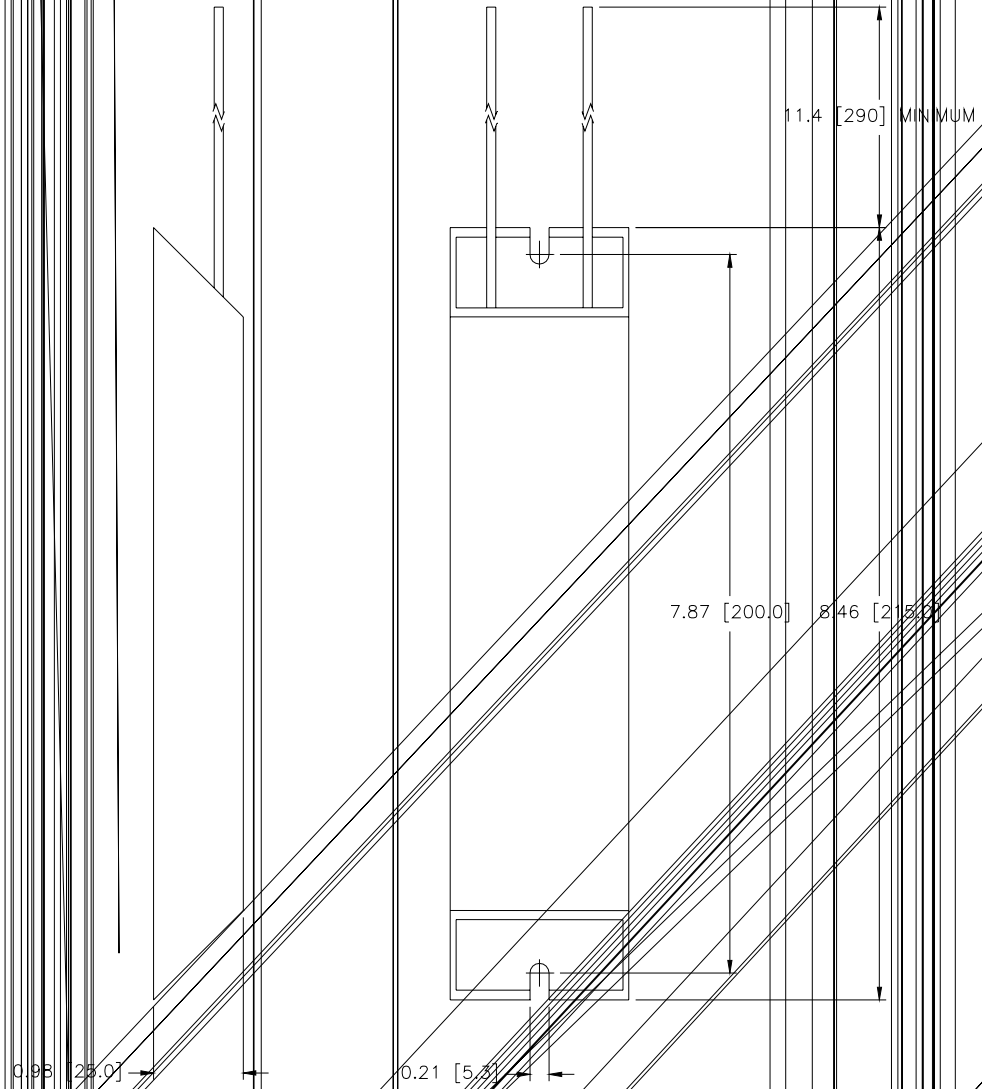

NOTES:

- 1.) RESISTOR MUST BE MOUNTED ON A FLAT SURFACE AT LEAST 12" X 12" IN FREE AIR TO MEET THE 200 WATT POWER DISSIPATION.
- 2.) THIS RESISTOR IS NOT UL OR CE APPROVED.
- 3.) RESISTOR MUST BE SECURELY MOUNTED ON LARGE HEATSINK SUCH AS ENCLOSURE WALL OR BACKPANEL.

SPECIFICATIONS

| | |
|------------------------|-----------|
| RESISTANCE: | 20 Ohms |
| CONTINUOUS POWER: | 400 Watts |
| MAXIMUM VOLTAGE: | 425 VDC |
| MAXIMUM PULSE CURRENT: | 22 A |
| MAXIMUM RMS CURRENT: | 4.5 A |
| DUTY CYCLE | 15 % |

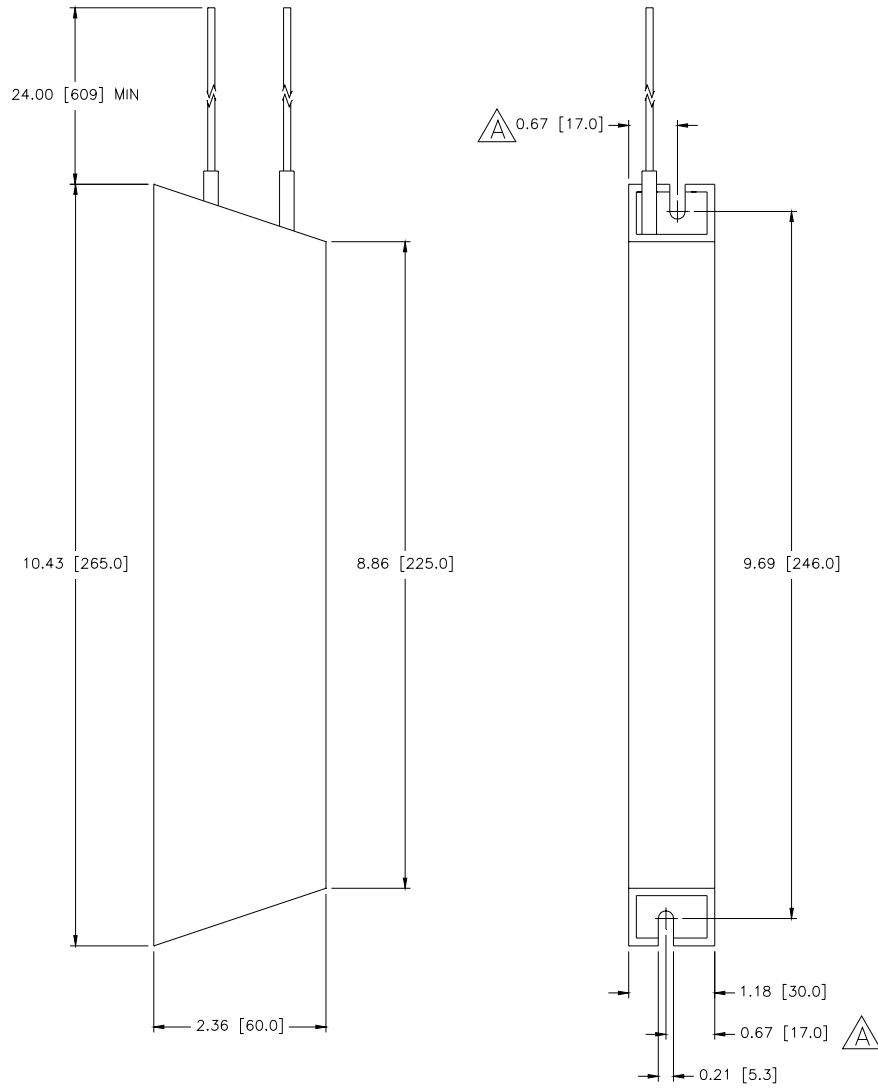

INDUSTRIAL INDEXING SYSTEMS, Inc.

www.iis-servo.com

TITLE

REGEN RESISTOR

DRAWING NUMBER

DRGN-20/400

DIMENSIONS ARE INCHES [mm]

TOLERANCES X.XX±0.01

X.XXX±0.005

± 5'

REV A

ECN 01-259

DATE 28JUN01

SH. 1 OF 1

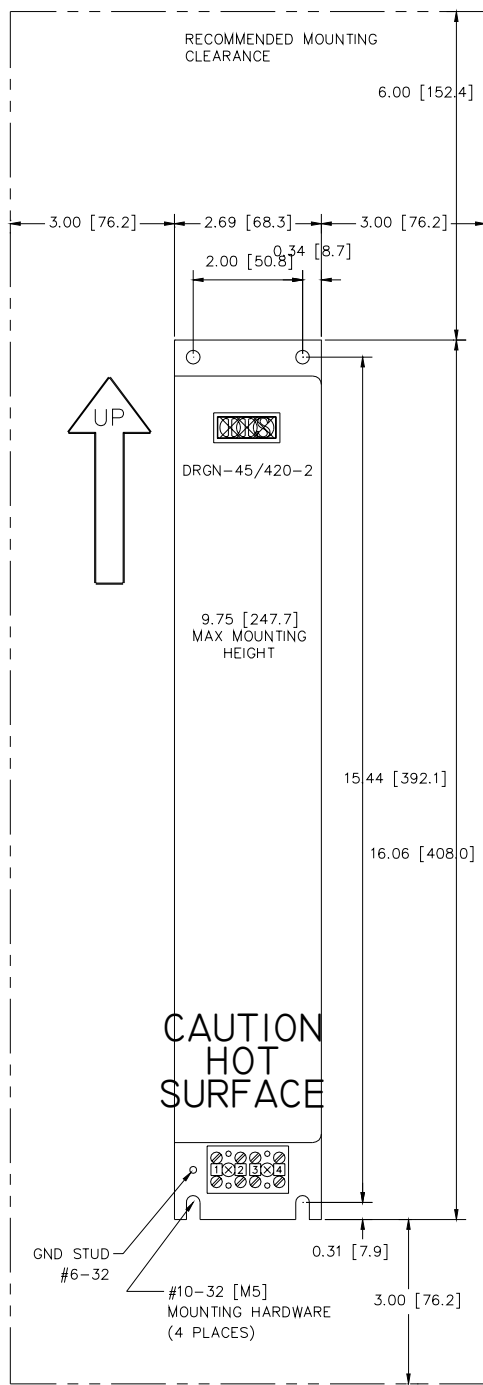

| SPECIFICATIONS | |
|------------------------|-----------|
| RESISTANCE: | 45 Ohms |
| CONTINUOUS POWER: | 420 Watts |
| MAXIMUM VOLTAGE: | 425 VDC |
| MAXIMUM PULSE CURRENT: | 9.5 A |
| MAXIMUM RMS CURRENT: | 3.1 A |
| DUTY CYCLE | 15% |

SCHMATIC

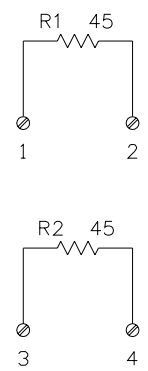

INDUSTRIAL INDEXING SYSTEMS, Inc.
www.iis-servo.com

TITLE
REGEN RESISTOR

DRAWING NUMBER
DRGN-45/420-2

| SPECIFICATIONS | |
|------------------------|-----------|
| RESISTANCE: | 22.5 Ohms |
| CONTINUOUS POWER: | 655 Watts |
| MAXIMUM VOLTAGE: | 425 VDC |
| MAXIMUM PULSE CURRENT: | 18.9 A |
| MAXIMUM RMS CURRENT: | 5.4 A |
| DUTY CYCLE: | 15% |

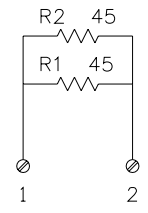
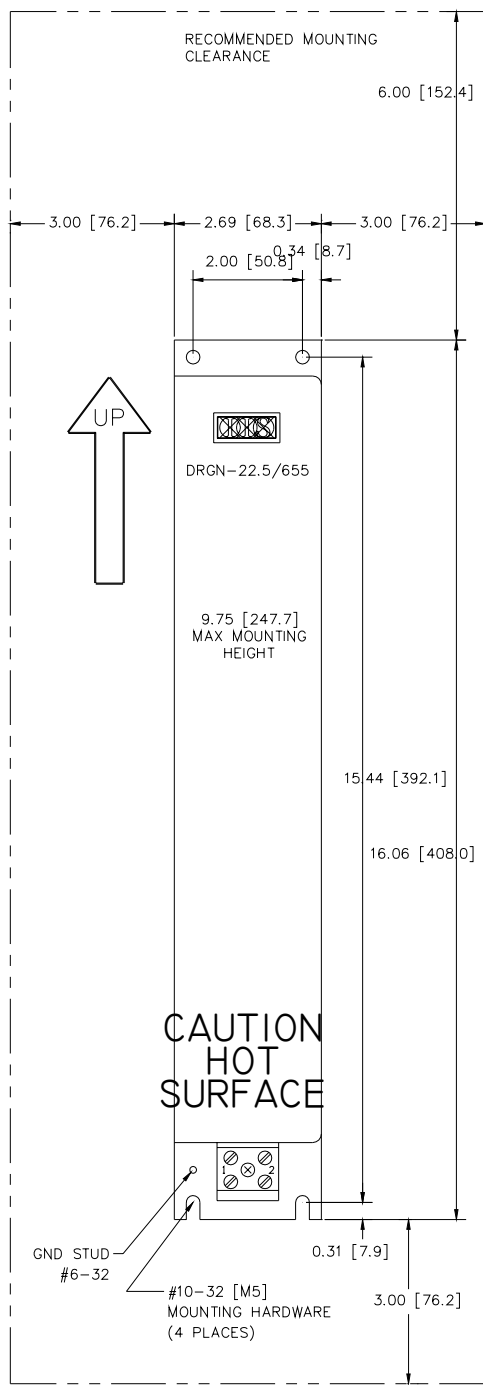

INDUSTRIAL INDEXING SYSTEMS, Inc.
www.iis-servo.com

TITLE
REGEN RESISTOR

DRAWING NUMBER
DRGN-22.5/655

| SPECIFICATIONS | |
|------------------------|-----------|
| RESISTANCE: | 15 Ohms |
| CONTINUOUS POWER: | 880 Watts |
| MAXIMUM VOLTAGE: | 425 VDC |
| MAXIMUM PULSE CURRENT: | 28.4 A |
| MAXIMUM RMS CURRENT: | 7.6 A |
| DUTY CYCLE | 15% |

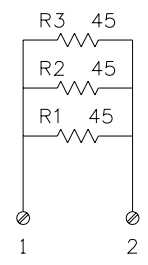
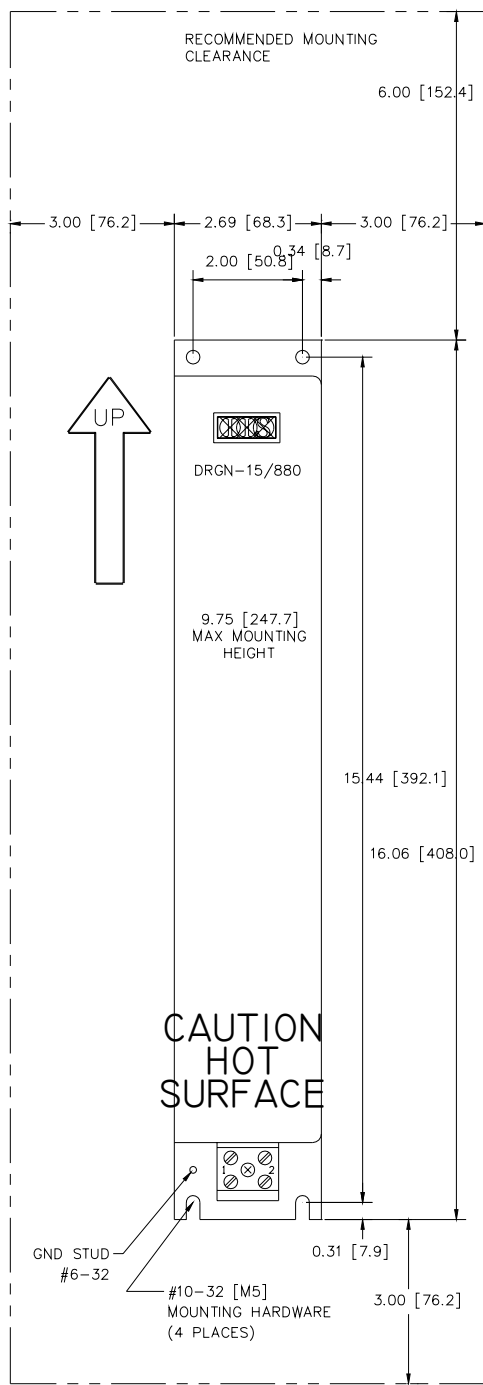

INDUSTRIAL INDEXING SYSTEMS, Inc.
www.iis-servo.com

TITLE
REGEN RESISTOR

DRAWING NUMBER
DRGN-15/880

| SPECIFICATIONS | |
|------------------------|------------|
| RESISTANCE: | 11.25 Ohms |
| CONTINUOUS POWER: | 1120 Watts |
| MAXIMUM VOLTAGE: | 425 VDC |
| MAXIMUM PULSE CURRENT: | 38.7 A |
| MAXIMUM RMS CURRENT: | 10 A |
| DUTY CYCLE | 15% |

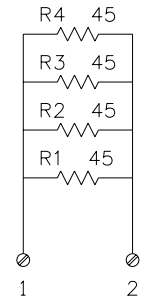
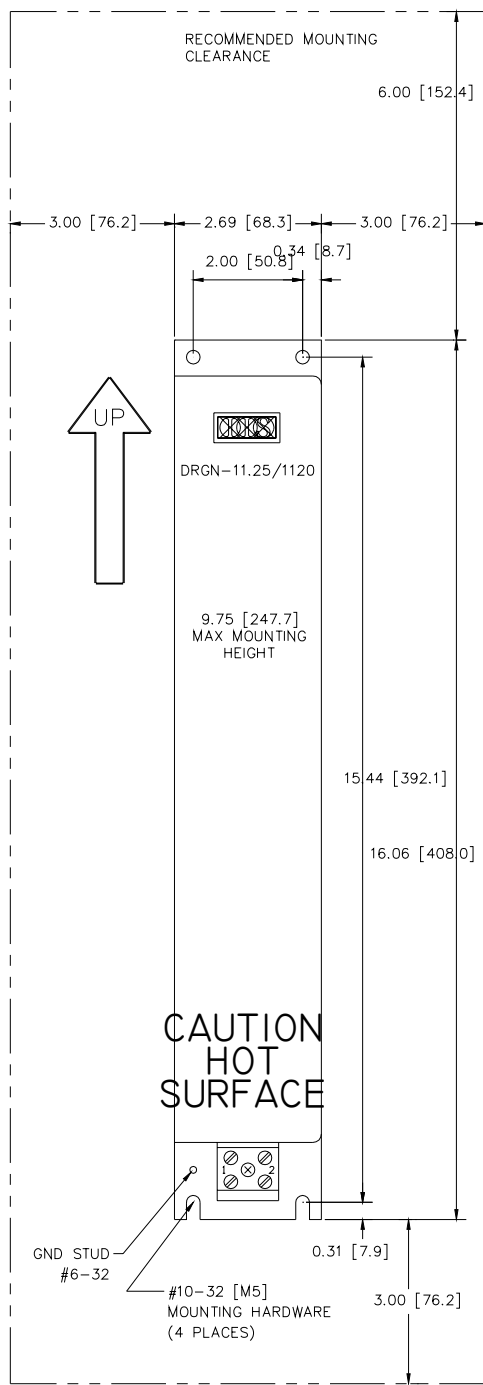

INDUSTRIAL INDEXING SYSTEMS, Inc.
www.iis-servo.com

TITLE
REGEN RESISTOR

DRAWING NUMBER
DRGN-11.25/1120