

## SECTION 12 - EMC INSTALLATION GUIDELINES FOR DELTA SERIES MOTORS AND DRIVERS

### 12.1 INTRODUCTION TO EMC GUIDELINES

This chapter provides guidance and requirements when installing IIS Delta Series motors and drivers into industrial control machinery required being CE marked. These guidelines are intended to provide the machine builder with the necessary EMC information, including parts and wiring techniques to comply with the European Community Standards for industrial control equipment. The final conformance to the standards for the overall machine remains the sole responsibility of the machine builder.

### 12.2 EMC REQUIREMENTS

In 1996, the European Community enacted standards concerning conducted and radiated emissions and immunity to various types of interference for industrial control equipment. The EMC Directive 89/336/EEC and harmonized standards define specific EMC levels and test procedures to gain conformance.

Emission Standards provide maximum levels of noise permitted to be generated by the equipment. Immunity Standards subject the equipment to various types of disturbances and verifies that the equipment continues to perform in a safe manner.

The IIS Delta Series motors and drivers have been tested and have been shown to comply with the following standards when installed per the guidelines in this section.

#### EMISSIONS STANDARDS:

EN55011 Class A	Power line conducted noise
EN55011 Class A	Radiated noise

#### IMMUNITY STANDARDS:

EN61000-4-2	Static discharge
ENV50140 & ENV50204	Electromagnetic irradiation
EN61000-4-4	Burst noise injected into power and signal wiring
EN61000-4-5	Lightning surge into power line
ENV50141	RF frequency injection into power and signal wiring
EN61000-4-8	Power frequency magnetic field
EN61000-4-11	Power line fluctuation and drop out

### 12.3 CONTROL ENCLOSURE

The Delta Series drivers must be installed in a suitable control enclosure that provides a good quality ground system and tight construction. The cabinets can be of welded construction, metal to metal conductive joints or have overlapping EMC gasketed joints. All joints and removable panels must have metal-to-metal ground contact. All hinged panels or doors must have a bonded ground wire from the hinged panel to the main body of the enclosure.

## 12.4 ENCLOSURE MOUNTING PANEL

It is highly recommended that a galvanized panel be used. Galvanized panels provide a continuous conductive surface that provides a low impedance ground plane for mounting the servo components.

The mounting panel must be grounded to the control enclosure with metal to metal joints, bolted together with external tooth lock washers or have multiple short ground jumper wires between the panel and the enclosure.

Painted panels can be used if the mounting area for the servo components and all grounding points have been masked off or have the paint removed.

All servo components that require grounding must use fasteners with external tooth lock washers.

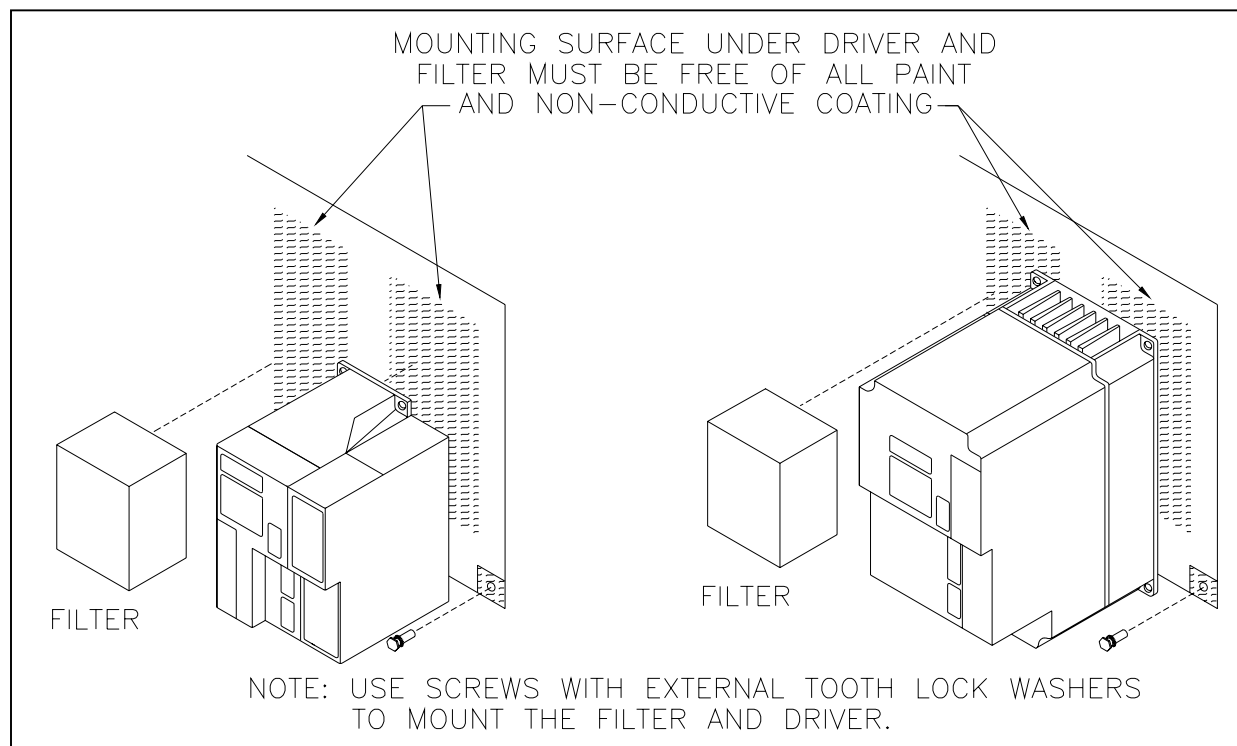

**Figure 12.1 - Enclosure Mounting Panel**

## 12.5 POWER LINE FILTER

A filter must be installed between the Delta Series Driver and the incoming power line to prevent conducted noise for getting onto the power line. It is recommended that a separate filter be used for each driver but it is possible to use a single larger filter to supply multiple drivers if the wiring between the filter and drivers is kept as short as possible.

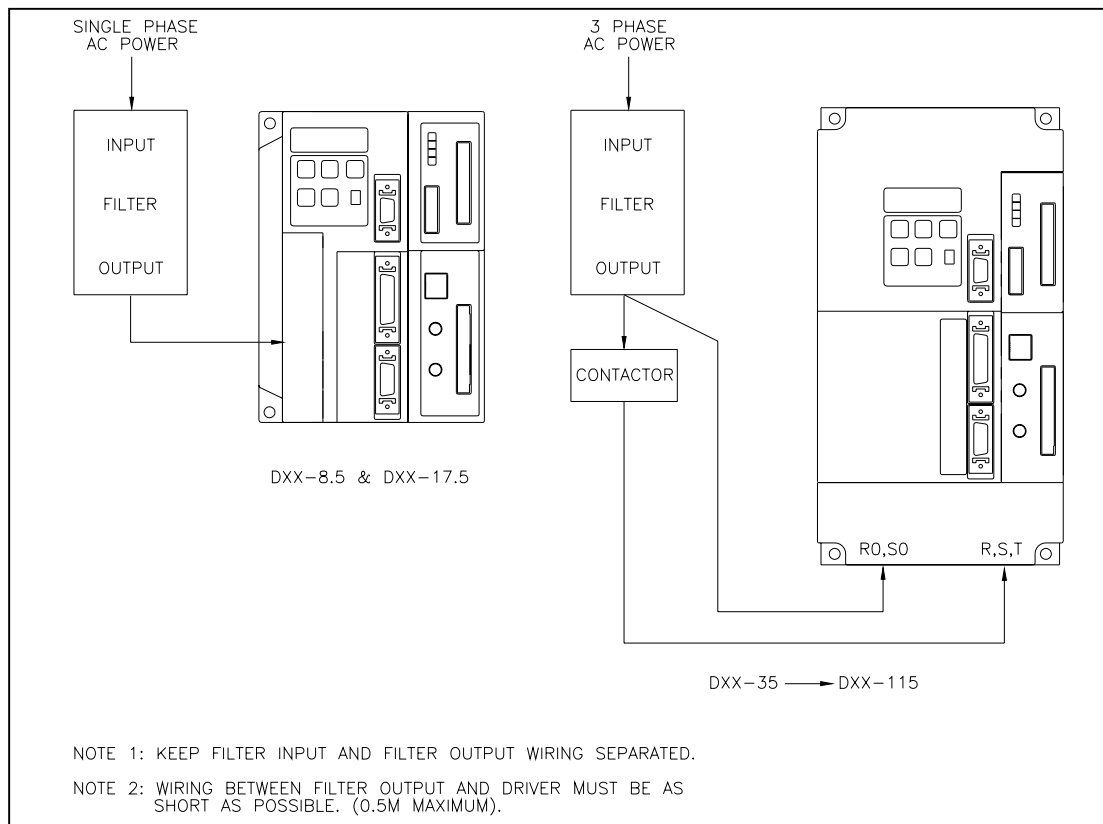

**Figure 12.2 - Power Line Filter**

The following power line filters are recommended for use with the Delta Series motors and drivers:

Total Motor Capacity	Phase	SOSHIN ELECTRONICS
500W max.	1	HF2010A-PI
500W -> 1000W	1	HF2015A-PI
1000W -> 1800W	3	HF3010A-PI
1800W -> 2600W	3	HF3020A-PI
2600W -> 3700W	3	HF3030A-PI
3700W -> 6500W	3	HF3040A-PI
6500W -> 11000W	3	HF3060A-TMA

Total Motor Capacity	Phase	SCHAFFNER ELECTRONIC AG
500W max.	1	FN 2070-3
500W -> 1000W	1	FN 2070-6
1000W -> 2200W	3	FN 258-16
2200W -> 3700W	3	FN 258-30
3700W -> 6500W	3	FN 258-42
6500W -> 11000W	3	FN 258-55

## 12.6 DRIVER OUTPUT (MOTOR ARMATURE) FILTER

The Delta Series Driver uses pulse width modulation (PWM) control of the motor windings. The PWM switching of the motor output generates transient voltages that must be suppressed before exiting the control enclosure. A simple ferrite core can be used as shown below.

The following ferrite core filters are recommended for use with the Delta Series motors and drivers:

Drive Size	Manufacturer	Part Number
DSD-1.5 -> DSD-70	TDK Corp.	ZCAT3035-1330
DSD-115	TOKIN Corp.	ESD-R-47DB

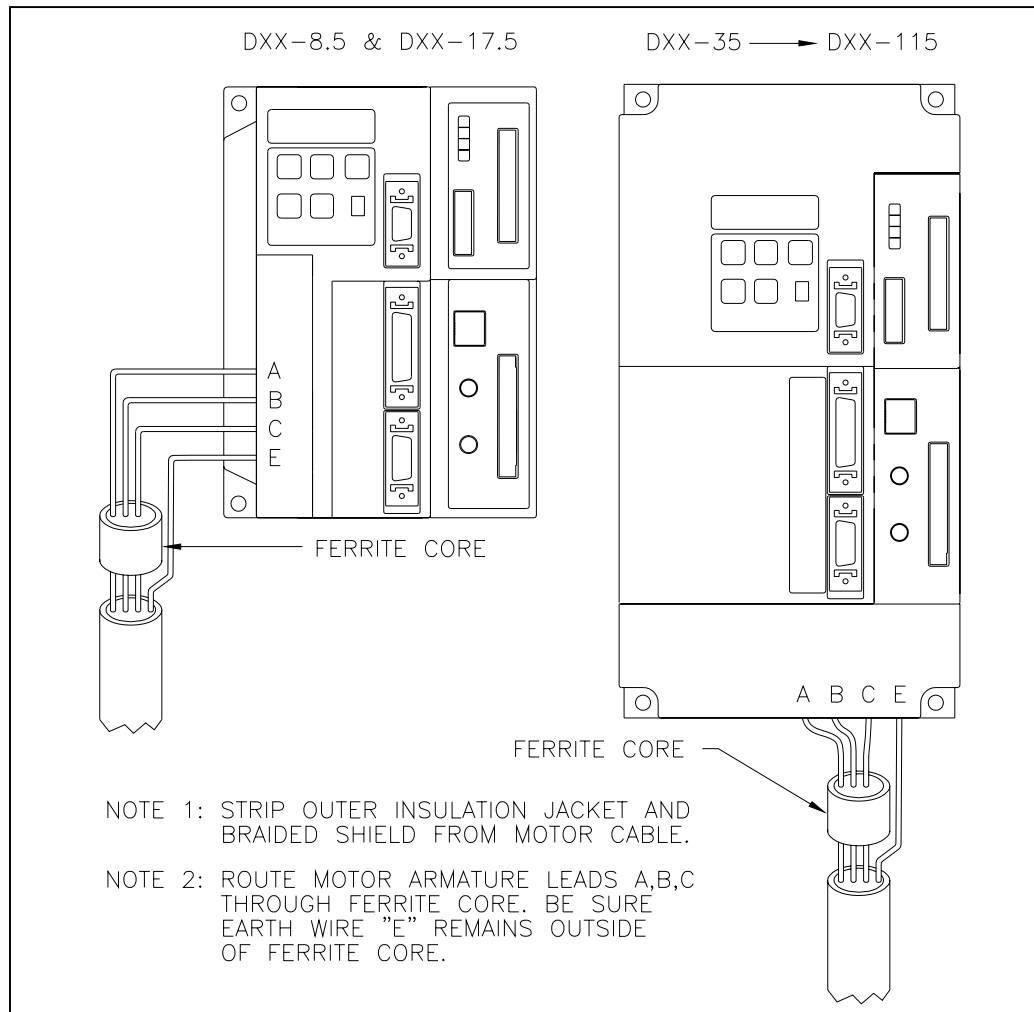

**Figure 12.3 - Driver Output (Motor Armature) Filter**

## 12.7 SHIELDED MOTOR CABLE

The motor armature cable between the driver and motor must be shielded and grounded at both the driver and motor end. The motor armature cable length between the control enclosure and motor must be less than 50 meters or additional shield is necessary. The following shielded motor armature wire is recommended.

Motor Capacity	TAIYO Electric	OFLEX	BELDEN
500W max.	VCT-SB0.75SQ4C	891804CY	7411AS
500W -> 1000W	VCT-SB1.25SQ4C	891604CY	7423AS
1000W -> 1800W	VCT-SB2.0SQ4C	891404CY	7436AS
1800W -> 2600W	VCT-SB3.5SQ4C	891204CY	7445AS
2600W -> 3700W	VCT-SB5.5SQ4C	891004CY	7447AS
3700W -> 11000W	VCT-SB14SQ4C	N/A	7450AS

Figures 12.4 and 12.5 show the recommended technique for grounding the motor armature cable.

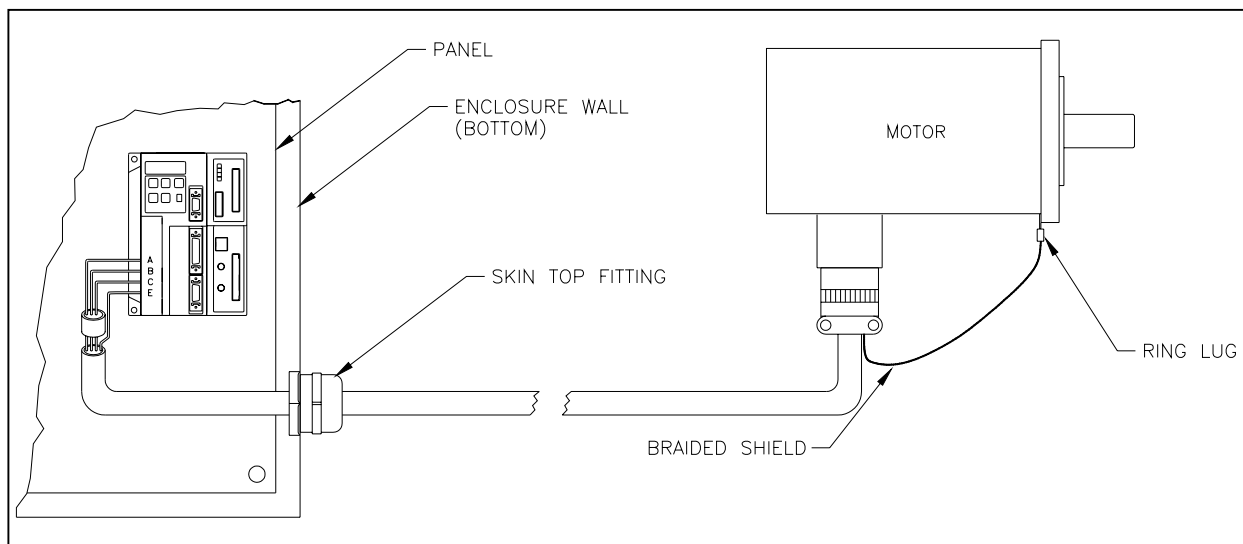

Figure 12.4 - Grounding Motor Armature Cable

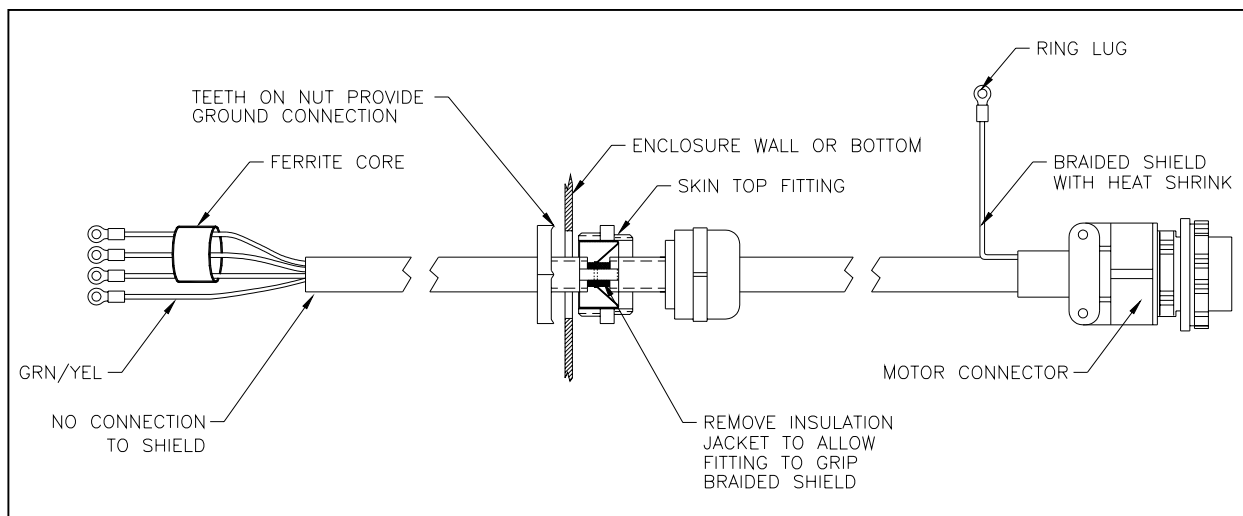

Figure 12.5 - Grounding Motor Armature Cable

## 12.7 SHIELDED MOTOR CABLE (cont'd)

The ground fittings shown in the figures above are made by OFLEX. The fittings are OFLEX SKINTOP MS-SC series P/N 5311-22x0; where x is a code for the wire diameter.

Figures 12.6 and 12.7 show an alternate method to ground the motor armature cable shield using saddle clamps.

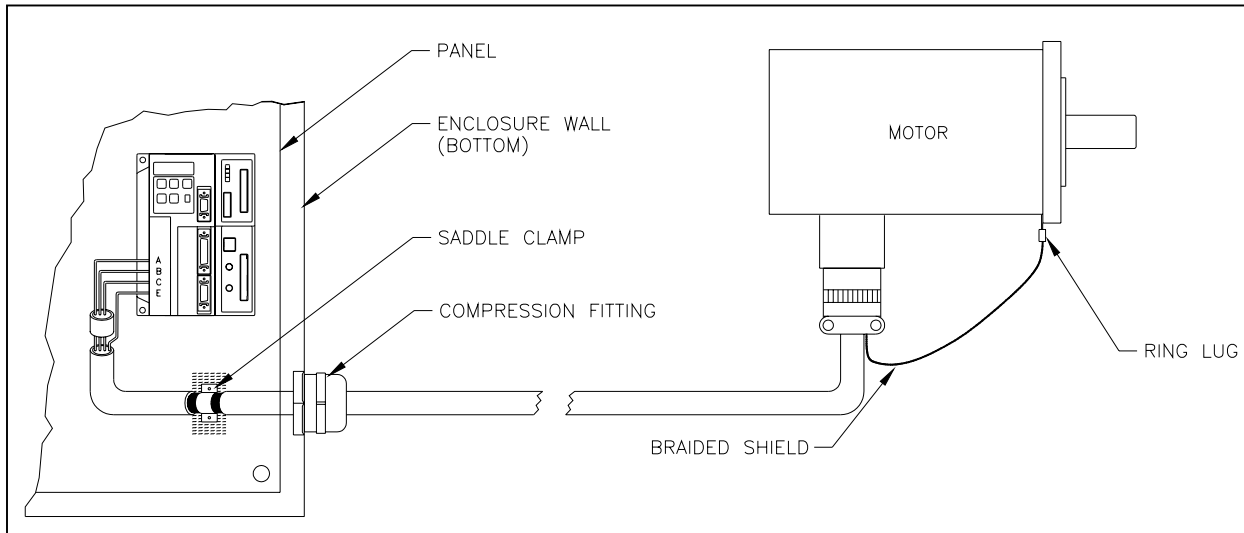

Figure 12.6 - Alternate Method to Ground the Motor Armature Cable

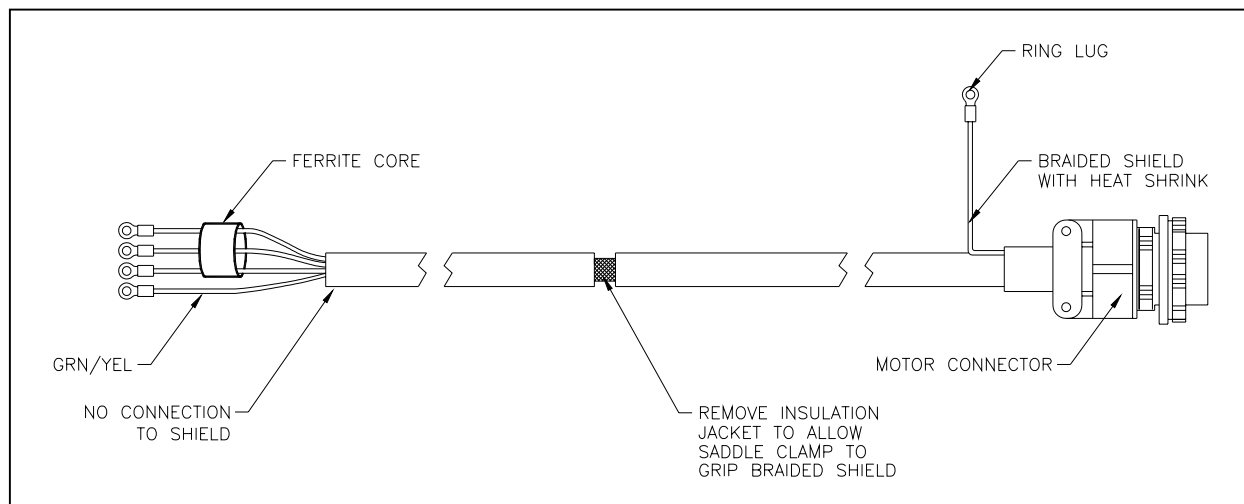

Figure 12.7 - Alternate Method to Ground the Motor Armature Cable

## 12.8 REGENERATION RESISTOR WIRING (OPTION)

If the regeneration resistor is located in the same enclosure as the driver, shielded wire is not necessary if the wiring is kept as short as possible. If the regeneration resistor is located in another enclosure, the regeneration resistor wire must be shielded and grounded in both enclosures. The SKINTOP ground fittings are shown in [Figure 12.8](#) but the saddle clamp method of grounding can also be used as shown in [Figure 12.9](#).

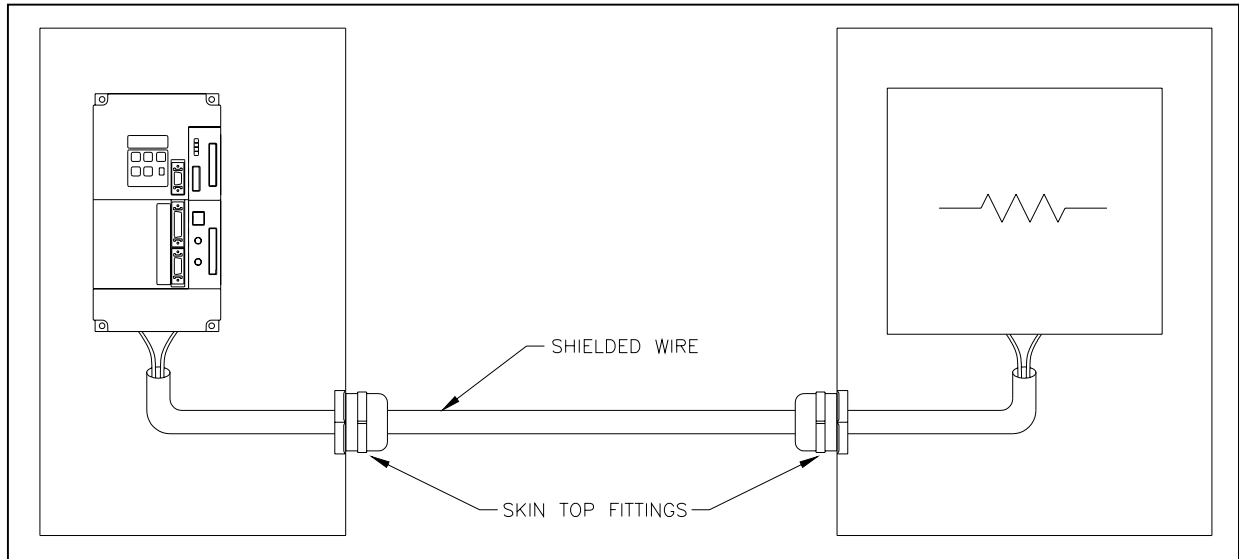

Figure 12.8 - SKINTOP Ground Fittings

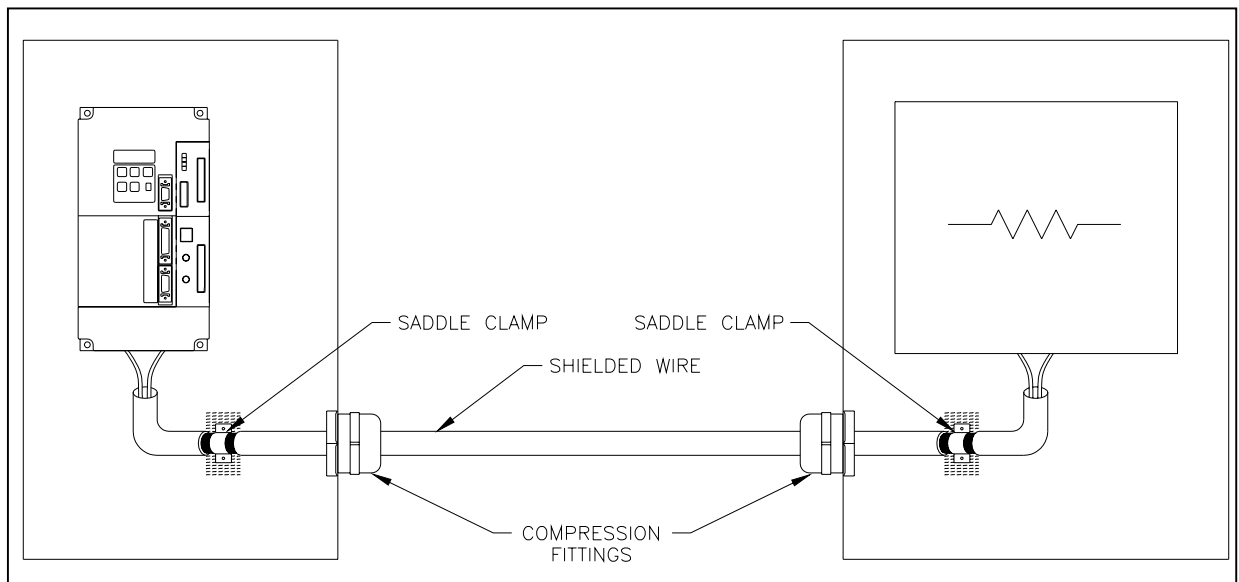

Figure 12.9 - Saddle Clamp Method of Grounding

## 12.9 DIGITAL CONTROL SIGNALS

High speed, fast rise time signals used with the Delta driver, such as command pulse inputs or pulse outputs, radiate high frequency noise. This noise must be suppressed to prevent excessive EMC radiation.

If the positioning controller and Delta driver are in the same control enclosure, the cable between the two must be shielded and grounded at both ends. If the positioning controller is located in a separate control enclosure, the cable between enclosures must be a braided shielded cable with both enclosure entries grounded with SKINTOP fittings or saddle clamps.