

INDUSTRIAL INDEXING SYSTEMS



DELTA SERIES™

DeltaPro™ Positioning Systems



DeltaPro Single Axis Positioning Systems

Here's motion control that's simple to spec, simple to understand and simple to use. It's DeltaPro from IIS, our compact, integrated positioning systems that combine everything you need for motion control: closed loop positioner/drive/power supply, operator interface, cables and motor, everything. These systems are specifically designed for applications like indexing, positioning, profiling, electronic gearing and other operations where complex programming is not required.

DeltaPro features 24 digital I/O, all 24 VDC optically isolated for reliable interface with machine functions and PLCs (Table 1). Seven I/Os (4 in, 3 out) are dedicated to common functions such as Jog Direction, Reset, etc. And 17 I/O (12 in, 5 out) are programmable in any way required. Two RS-232 ports allow communication with the OPI-50 operator interface, PLC or computer. And there's two analog inputs and one output. And

DeltaPro also offers an optional high speed CAN bus serial port, allowing for DeviceNet™ network connections.



DeltaPro can use an optional resolver or encoder as a master follower for electronic gearing functions and programmable limit switch functions by using the

high speed fiber optic input port.

This system is perfect for standalone single axis motion control. The built-in functions include positioning, indexing, S-curve profiles, electronic gear ratios, profile sequences, timers, repeats, search for sensors, I/O control and others. Inputs can be configured as a binary coded trigger to execute up to 127 motion program blocks - an excellent strategy for simple PLC interfaces.

Programming is fast and simple and is handled through the OPI-50 touchpad operator interface or your PC connected to an RS-232 port. Plain language on-screen menus walk you through the entire process one step at a time. In just minutes you can have a complete, running program. It's that simple.

DeltaPro: high performance, affordably priced, easy to use motion control. It's what you'd expect from IIS.

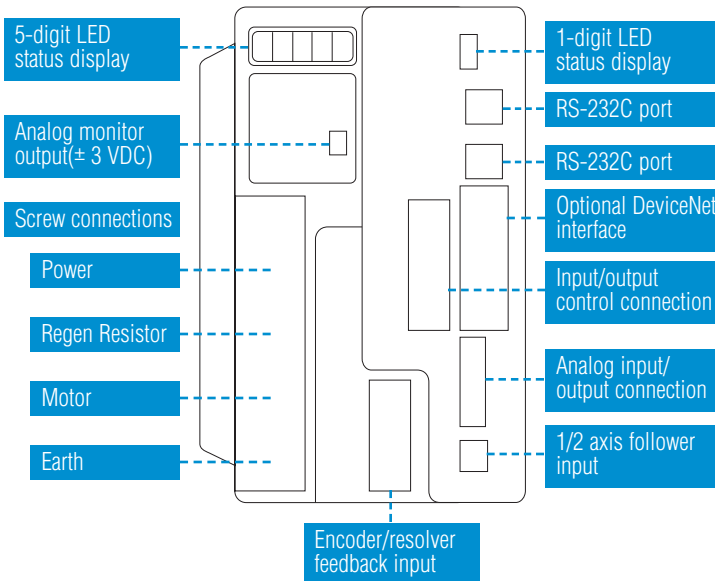

DeltaPro Specifications

- Processor: Two 32-bit RISC
- Flash ROM and NOVRAM memory
- Communications port: Two RS-232; optional DeviceNet
- Driver operating temperature 0-50°C
- Analog I/O: 10-bit resolution
- Analog range: (2) 0-5 VDC inputs; (1) 0-5 VDC output; (1) 5 VDC/5 mA analog reference
- Optically isolated inputs: 16 @ 24 VDC/5 mA
- Optically isolated outputs: 8 @ 24 VDC/500 mA
- Peak current available for 3 sec.
- Internal regen resistor on DPro-35 thru DPro-115
- Current, velocity and position loops closed digitally
- Feedback: resolver standard; encoder or absolute available
- Resolver resolution: 4,096 bits/rev
- Encoder feedback resolution: encoder dependent
- Output form: PWM 3Ø sine wave
- Motor ripple frequency: DPro8.5-50=20 kHz DPro70-115=10kHz

DeltaPro Features

- Closed loop servo system
- Fiber optic input for master/slave and PLS applications
- Compact, high power density motors from 120 W to 6500 W - ideal for tight spaces
- Easy menu-driven programming
- SMT circuit boards for compact, reliable operation
- High visibility 5-digit driver status display, 1-digit positioner status display
- Absolute master follower function
- Programmable Limit Switch (PLS)
- All digital electronics eliminates drift
- Auto servo tuning function

Cables and Accessories

The OPI-50 Touchpad Operator Interface provides a convenient way to control and program the DeltaPro.

Feedback and motor power cables are available in standard 20, 50 and 100-foot lengths. Various I/O cables, DIN rail I/O blocks and communications cables can be supplied.

Resolver, encoder and fiber optic converters and feedback components are available for master-slave applications.

Mechanical brakes, dynamic brakes and external regen resistors are also available.

DeltaPro is available with a high speed CAN bus serial port for DeviceNet connections.

DeltaPro Part Number	Peak Current(3 sec)	Continuous Driver Current	Supply Voltage Maximum Range
DPro-8.5/RA	8.5 A rms	3.4 A rms	170-264 VAC 50/60 Hz Single Phase
DPro-8.5/RB	8.5 A rms	2.1 A rms	85-126 VAC 50/60 Hz Single Phase
DPro-17.5/RA	17.5 A rms	5.7 A rms	170-264 VAC 50/60 Hz Single Phase
DPro-35/RA	35.0 A rms	14.1 A rms	170-264 VAC 50/60 Hz 3 Phase
DPro-50/RA	50.0 A rms	16.3 A rms	170-264 VAC 50/60 Hz 3 Phase
DPro-70/RA	70.0 A rms	24.8 A rms	170-264 VAC 50/60 Hz 3 Phase
DPro-115/RA	115.0 A rms	53.0 A rms	170-264 VAC 50/60 Hz 3 Phase

Fast, Simple Menu-Driven Programming Using Touchpad Operator Interface or Your PC

DeltaPro is designed for people who aren't computer programmers. The simple fill-in-the-blanks strategy makes it easy to construct programs in minutes. Here's how...

Connect DeltaPro to either the OPI-50 operator interface or your PC with our MotionPro™ for Windows™ software. Choose Set Up and the easy to use menu walks you through entering the basics such as Engineering Units and Jog Speed. Table 2 shows how easy it is.

Motion control programs are created by scrolling through the items in Table 3. Just select the instruction you want and fill in the parameters. Built-in default ranges and limits, error messages and on-line help keep you on track and out of trouble.

Each step tells DeltaPro what to do and how to move - Position, Index, Wait Time, Turn On I/O, and so forth. Each step has a parameter associated with it - speed, time, distance, etc. These could be specified as constants, inputs from the operator interface or as variables.

Variables can be free form user variables or predefined internal variables such as

analog input, motor position, etc. One of the RS-232 ports can be connected to a PC or PLC to read and write variables.

A series of steps is organized into a block. A program is made up of blocks, with each block directly related to a digital input. The block is executed when the input is energized. Special blocks can be executed at program start, program stop, fault sensing or on PLS trigger angles.

DeltaPro can store up to 200 steps, and these can be configured in a variable number of motion control program blocks.

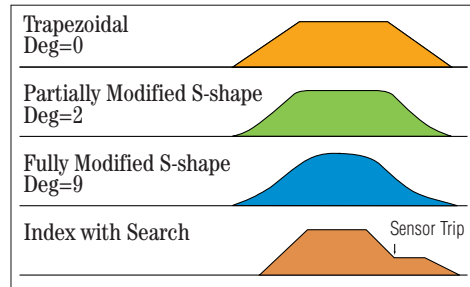

DeltaPro motion profiles are available from trapezoidal shapes to fully modified sine shapes.

DeltaPro executes motion profiles as a standard trapezoidal shape or a S-curve shape, with 10 degrees of modification available between the two. Trapezoidal profiling, with a degree of 0, is the most time efficient. The fully modified S-shape profile, with a degree of 9, provides S-curve profiling for smooth machine operation. A Search for I/O function adds a search tail on the motion profile for registering to a sensor.

DeltaPro's Programmable Limit Switch (PLS) function runs independently of the main program. PLS functions can be set, reset or modified in any program block while the PLS is running. And the PLS input can be electronically connected to the master follower input or to the servo motor position.

When you're ready to run, use the built-in real time Program Trace function to verify proper operation.

Congratulations! You've just built a motion control program, one step at a time...quickly, simply, without any programming language or computer knowledge. And you did it in minutes.

You've just used DeltaPro.



DeltaPro systems are available in a broad range of sizes from 120 W to 6500 W.

DeltaPro Programming Features

DeltaPro features two dozen digital I/O, all optically isolated 24 VDC to provide dependable interface with machine functions and PLCs. Of these 24, seven are dedicated to specific, common I/O functions. Four dedicated inputs allow you to switch from manual to automatic operation, jog in either direction, and reset the program. Three dedicated outputs notify you of program operational status.

Table 1:Dedicated Input/Output

I/O No.	Function	Active in		Description
		Man	Auto	
Input 13	Manual/Auto	<input checked="" type="checkbox"/>	<input checked="" type="checkbox"/>	Selects operation mode
Input 14	Jog CW	<input checked="" type="checkbox"/>		Jogs motor CW
Input 15	Jog CCW	<input checked="" type="checkbox"/>		Jogs Motor CCW
Input 16	Reset	<input checked="" type="checkbox"/>	<input checked="" type="checkbox"/>	Terminates motion/ resets program
Output 6	Profile Complete		<input checked="" type="checkbox"/>	Commanded profile complete
Output 7	Controller OK	<input checked="" type="checkbox"/>	<input checked="" type="checkbox"/>	Controller diagnostic status
Output 8	Block Executing		<input checked="" type="checkbox"/>	Program block is executing



Our convenient, hand-held OPI-50 Operator Interface, with its tactile membrane keypad and high visibility display, is used for machine data entry, diagnostics and programming.

An easy to use and complete selection of set-up options lets you tailor machine performance parameters to your exact requirements. Just choose the Set-Up Options menu on the OPI-50 or your PC and select the parameter you wish to modify. Change engineering units, jog speed, trigger mode, modify servo parameters and brake mode, limit torque, even change your system password.

Table 2:Set-up Options

Option	Parameter
Engineering Units	Machine units per motor revs
Jog Speed and Ramp	RPM and Rev/sec ²
Block Trigger Mode	Input or Binary
Motor Code	Motor Selection
Servo Parameters	Gain, Inertia Ratio, etc.
Brake Mode	None, Static, Dynamic
Test Point Function	Speed or Torque
Auto Tuning	Frequency Response
Erase Program Blocks	Yes/No
Password	Number
Torque Limit	%
Auto Start	Yes/No

Table 3:Programming Instructions

Instruction	Parameter	Fixed	Touchpad	Variable	Description
INITIALIZE	Speed Accel/Decel Z Rev. NO/IO#	<input checked="" type="checkbox"/> <input checked="" type="checkbox"/> <input checked="" type="checkbox"/>	<input checked="" type="checkbox"/> <input checked="" type="checkbox"/>	<input checked="" type="checkbox"/> <input checked="" type="checkbox"/>	Jogs motor to absolute 0.0 reference. Can be used with zero revolution limit switch for multi-turn applications.
CW LIMIT	IO#	<input checked="" type="checkbox"/>			Limits motor rotation in CW direction
CCW LIMIT	IO#	<input checked="" type="checkbox"/>			Limits motor rotation in CCW direction
POSITION	Absolute Position Top Speed Accel/Decel Degree	<input checked="" type="checkbox"/> <input checked="" type="checkbox"/> <input checked="" type="checkbox"/> <input checked="" type="checkbox"/>	<input checked="" type="checkbox"/> <input checked="" type="checkbox"/> <input checked="" type="checkbox"/> <input checked="" type="checkbox"/>	<input checked="" type="checkbox"/> <input checked="" type="checkbox"/> <input checked="" type="checkbox"/> <input checked="" type="checkbox"/>	An absolute move to the specified position relative to 0.0
INDEX	Incremental Distance Top Speed Accel/Decel Degree	<input checked="" type="checkbox"/> <input checked="" type="checkbox"/> <input checked="" type="checkbox"/> <input checked="" type="checkbox"/>	<input checked="" type="checkbox"/> <input checked="" type="checkbox"/> <input checked="" type="checkbox"/> <input checked="" type="checkbox"/>	<input checked="" type="checkbox"/> <input checked="" type="checkbox"/> <input checked="" type="checkbox"/> <input checked="" type="checkbox"/>	An incremental move of a specified distance relative to current position
SEARCH FOR I/O	I/O# ON/OFF Search Dist. max. Post I/O Distance Speed	<input checked="" type="checkbox"/> <input checked="" type="checkbox"/> <input checked="" type="checkbox"/> <input checked="" type="checkbox"/>	<input checked="" type="checkbox"/> <input checked="" type="checkbox"/> <input checked="" type="checkbox"/> <input checked="" type="checkbox"/>	<input checked="" type="checkbox"/> <input checked="" type="checkbox"/> <input checked="" type="checkbox"/> <input checked="" type="checkbox"/>	A continuation of a move until an I/O is turned ON/OFF or the maximum search distance is reached. After the I/O trigger the servo moves the Post I/O Distance.
SET 0.0	-				Force current position to 0.0 (Floating Home)
CLR 0.0	-				Clears the SET 0.0 floating home back to absolute 0.0 initialize home
WAIT TIME	Time in ms.	<input checked="" type="checkbox"/>	<input checked="" type="checkbox"/>	<input checked="" type="checkbox"/>	Programmed delay
WAIT TILL STOP	-				Programmed wait until the current motion command is complete.
WAIT POSITION	Position	<input checked="" type="checkbox"/>	<input checked="" type="checkbox"/>	<input checked="" type="checkbox"/>	Programmed wait until the servo reaches the absolute position specified or until the current motion command is complete.
WAIT DISTANCE	Distance	<input checked="" type="checkbox"/>	<input checked="" type="checkbox"/>	<input checked="" type="checkbox"/>	A programmed wait until the servo travels the incremental distance specified or until the current motion command is complete.
WAIT I/O	I/O# or PLS# ON/OFF	<input checked="" type="checkbox"/>			A programmed wait until the I/O or PLS condition is true.
TURN ON/OFF	I/O# DRIVE	<input checked="" type="checkbox"/> <input checked="" type="checkbox"/>			Turn ON/OFF the specified output or servo drive power
PRESET BATCH	Count	<input checked="" type="checkbox"/>	<input checked="" type="checkbox"/>	<input checked="" type="checkbox"/>	Sets starting count for batch counter function
DO WHILE	I/O# or PLS# Count Batch Until Exit	<input checked="" type="checkbox"/> <input checked="" type="checkbox"/> <input checked="" type="checkbox"/> <input checked="" type="checkbox"/>	<input checked="" type="checkbox"/> <input checked="" type="checkbox"/> <input checked="" type="checkbox"/> <input checked="" type="checkbox"/>	<input checked="" type="checkbox"/> <input checked="" type="checkbox"/> <input checked="" type="checkbox"/> <input checked="" type="checkbox"/>	Repeat the instruction between the DO WHILE and END WHILE until the specified condition is true.
END WHILE	-				Termination of DO WHILE LOOP
IF I/O	I/O# or PLS# Step #	<input checked="" type="checkbox"/> <input checked="" type="checkbox"/>			Go to another step within the current block if specified condition is true.
FOLLOWER	Master gear Slave gear Lock/Unlock Accel/Decel	<input checked="" type="checkbox"/> <input checked="" type="checkbox"/> <input checked="" type="checkbox"/> <input checked="" type="checkbox"/>	<input checked="" type="checkbox"/> <input checked="" type="checkbox"/> <input checked="" type="checkbox"/> <input checked="" type="checkbox"/>	<input checked="" type="checkbox"/> <input checked="" type="checkbox"/> <input checked="" type="checkbox"/> <input checked="" type="checkbox"/>	Set the electronic gear ratio between the master follower and servo and method of engaging and disengaging servo lock. Accel/decel limit is applied to follower.
LET	Values Function	<input checked="" type="checkbox"/> <input checked="" type="checkbox"/>	<input checked="" type="checkbox"/> <input checked="" type="checkbox"/>	<input checked="" type="checkbox"/> <input checked="" type="checkbox"/>	Allows arithmetic operations on variables (+, -, *, /)
IF VARIABLE	Values Function Step#	<input checked="" type="checkbox"/> <input checked="" type="checkbox"/> <input checked="" type="checkbox"/>	<input checked="" type="checkbox"/> <input checked="" type="checkbox"/> <input checked="" type="checkbox"/>	<input checked="" type="checkbox"/> <input checked="" type="checkbox"/> <input checked="" type="checkbox"/>	Go to another step within the current block if the specified condition is true. (=, <, >, <=, >=, <>)
SET PLS ANGLE	PLS# Enable/Disable Source ON Angle OFF Angle I/O# or NONE	<input checked="" type="checkbox"/> <input checked="" type="checkbox"/> <input checked="" type="checkbox"/> <input checked="" type="checkbox"/> <input checked="" type="checkbox"/> <input checked="" type="checkbox"/>	<input checked="" type="checkbox"/> <input checked="" type="checkbox"/> <input checked="" type="checkbox"/> <input checked="" type="checkbox"/> <input checked="" type="checkbox"/> <input checked="" type="checkbox"/>	<input checked="" type="checkbox"/> <input checked="" type="checkbox"/> <input checked="" type="checkbox"/> <input checked="" type="checkbox"/> <input checked="" type="checkbox"/> <input checked="" type="checkbox"/>	Turns on PLS# output when the source is between the specified ON and OFF angles. Source can be master follower or servo. The PLS# can also cause a physical output to turn ON and OFF.
EXIT BLOCK	-				

Typical DeltaPro Applications

A feed, punch and cut system is easily accomplished by connecting the operator RUN/STOP switch to INPUT #2 and configuring the other I/O as shown. When the operator selects RUN the DO WHILE sequence in Block #2 is executed until RUN

is turned OFF. The punch, cut and feed sequence is controlled by the DeltaPro program. Note that the servo feed has a search section that is terminated by the photo registration sensor thereby registering the mark on the web to the hole and cut.

Instruction Step	Parameters	Comments
2.1 DO WHILE	INPUT #2 ON	Repeat through END WHILE until INPUT #2 (RUN) is OFF
2.2 TURN ON	OUTPUT #1	Turn ON the punch before the feed
2.3 TURN ON	OUTPUT #2	Also turn ON cutter
2.4 WAIT TIME	TIME=200ms	Wait until punch and cutter are extended
2.5 TURN OFF	OUTPUT #1	Turn OFF the punch
2.6 TURN OFF	OUTPUT #2	Turn OFF cutter
2.7 WAIT TIME	TIME=200ms	Wait until punch is retracted
2.8 SEARCH FOR I/O	INPUT #3 ON 0.5" 0.0" 100 RPM	Search for register mark on the web at 100 RPM. Stop after 0.5" if mark is not seen. Start searching during next motion command.
2.9 INDEX	DIST=3.000" SPEED=800 RPM AC/DC=200 R/S/S DEG=0	Feed web 3" using trapezoidal motion profile
2.10 WAIT TILL STOP		Wait until servo motor comes to rest
2.11 END WHILE		Go back to Step 2.1 and check INPUT #2
2.12 EXIT BLOCK		INPUT #2 (RUN) is OFF so stop automatic run cycle

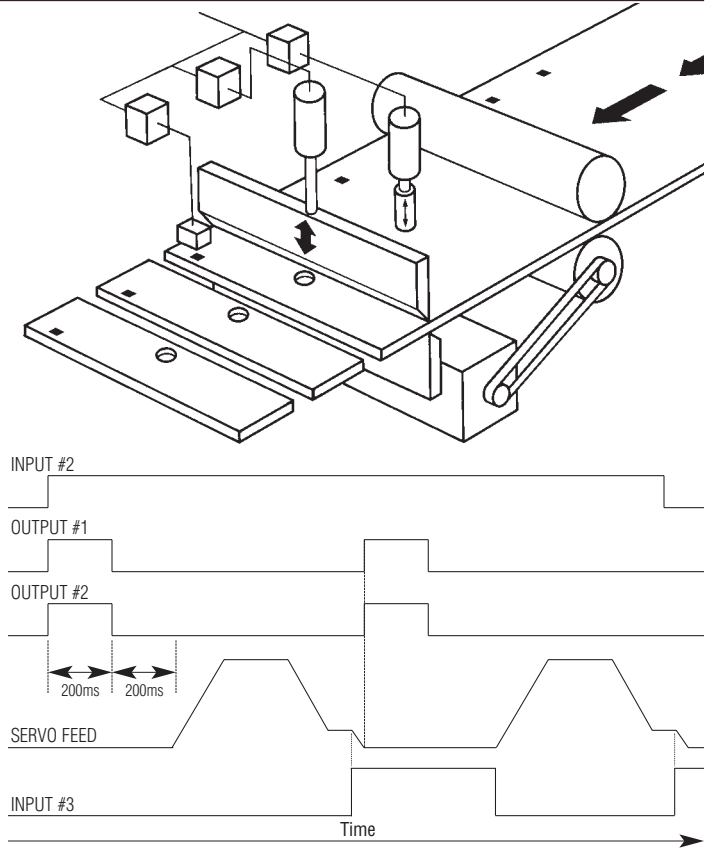

A constant pitch winder system is programmed using 11 simple DeltaPro programming instructions. The operator RUN/STOP switch is connected to INPUT #4 and when turned ON the program sequence in Block #4 executes. The traverse motion operation is controlled

using the electronic gearbox feature of the DeltaPro. A resolver or encoder on the winder spool shaft is the master that controls movement of the traverse axis thereby guaranteeing a consistent wind at all spool speeds. If RUN/STOP is turned OFF the wind sequence is aborted.

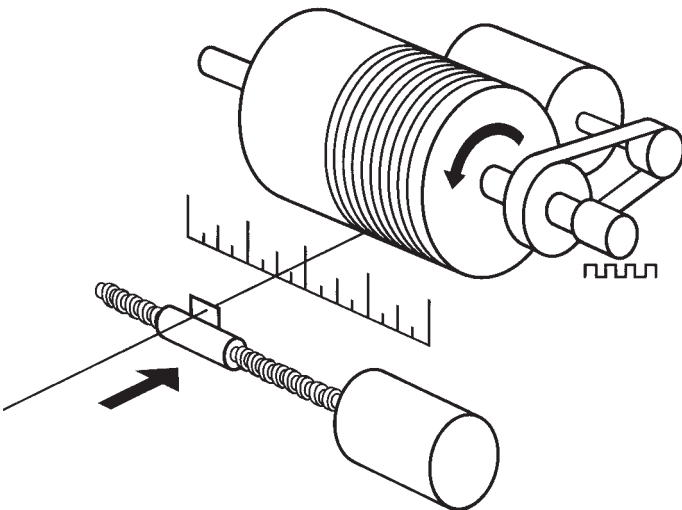

Instruction Step	Parameters	Comments
4.1 TURN ON	OUTPUT #1	Start drum motor to begin winding
4.2 DO WHILE	COUNT=40	Do 40 out and back cycles(80 layers)
4.3 FOLLOWER	MASTER GEAR=10 SLAVE GEAR=100 LOCK=ON AC/DC=300	Use electronic gearbox with ratio of 10:1 to drive traverse motor. Electronic ratio controls the pitch of the wind. Start motion toward 4.000" position
4.4 WAIT POSITION	POS=4.000	Keep moving traverse toward 4.000" position until 4.000" position is reached
4.5 FOLLOWER	MASTER GEAR=-10 SLAVE GEAR=100 LOCK=ON AC/DC=300	Reverse the electronic gearbox by putting a minus sign on the master gear entry. This counter rotation moves the traverse back toward 0.000" position
4.6 WAIT POSITION	POS=0.000	Keep moving traverse toward 0.000" position until 0.000" is reached
4.7 IF I/O	INPUT #4 OFF STEP 4.9	If RUN/STOP is turned off abort the wind
4.8 END WHILE		Increment count by 1, check if count=40
4.9 TURN OFF	OUTPUT #1	Done with 80 repeats so stop drum motor
4.10 FOLLOWER	MASTER GEAR=-10 SLAVE GEAR=100 LOCK=OFF AC/DC=300	Stop traverse motion at 0.000" position
4.11 EXIT BLOCK		

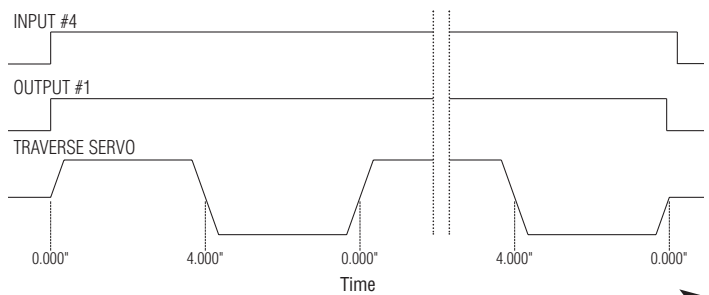

DeltaPro DPro-8.5 Motor and Integrated Drive/Controller Packages

DeltaPro Package	Motor Part Number	DeltaPro Part Number	Power Output Watts	Rated Speed RPM	Max Speed RPM	Rated Torque			Peak Torque			Rotor Inertia		
						N-M	Lb-in	Lb-ft	N-M	Lb-in	Lb-ft	Kg-cm ²	Lb-in-sec ²	Lb-ft-sec ²
DeltaPro-120HRA	DBM-120/30R	DPro-8.5/RA	120	3000	4000	0.38	3.36	0.28	1.03	9.12	0.76	0.103	0.000091	0.0000076
DeltaPro-120HRB	DBM-120/30R	DPro-8.5/RB	120	3000	4000	0.38	3.36	0.28	1.03	9.12	0.76	0.103	0.000091	0.0000076
DeltaPro-200HRA	DBM-200/30R	DPro-8.5/RA	200	3000	4000	0.64	5.66	0.47	1.76	15.58	1.30	0.148	0.000131	0.0000109
DeltaPro-200HRB	DBM-200/30R	DPro-8.5/RB	200	3000	4000	0.64	5.66	0.47	1.76	15.58	1.30	0.148	0.000131	0.0000109
DeltaPro-400LRA	DBM-400/15R	DPro-8.5/RA	400	1500	2000	2.55	22.57	1.88	7.35	65.05	5.42	0.760	0.000673	0.0000561
DeltaPro-400HRA	DBM-400/30R	DPro-8.5/RA	400	3000	4000	1.27	11.24	0.94	3.53	31.24	2.60	0.233	0.000206	0.0000172
DeltaPro-500HRA	DBM-500/30R	DPro-8.5/RA	500	3000	4000	1.59	14.07	1.17	4.20	37.17	3.10	0.470	0.000416	0.0000347

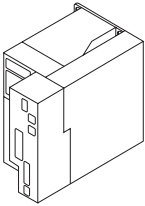

Dimensions

	in.	(mm.)
Panel height	6.70	170
Panel width	4.65	118
Depth off panel	8.00	203

DeltaPro Package	Motor Part Number	Motor Length		Mounting Face (Sq)		Shaft Length		Shaft Diameter		Motor Weight		Resolver Cable	Motor Cable
		mm	in	mm	in	mm	in	mm	in	kg	lbs		
DeltaPro-120HRA	DBM-120/30R	105	4.13	60	2.36	30	1.18	14	0.551	1.0	2.2	C-245YYY	C-686YYY
DeltaPro-120HRB	DBM-120/30R	105	4.13	60	2.36	30	1.18	14	0.551	1.0	2.2	C-245YYY	C-686YYY
DeltaPro-200HRA	DBM-200/30R	122	4.80	60	2.36	30	1.18	14	0.551	1.3	2.9	C-245YYY	C-686YYY
DeltaPro-200HRB	DBM-200/30R	122	4.80	60	2.36	30	1.18	14	0.551	1.3	2.9	C-245YYY	C-686YYY
DeltaPro-400LRA	DBM-400/15R	190	7.48	95	3.74	45	1.77	19	0.748	4.5	9.9	C-246YYY	C-687YYY
DeltaPro-400HRA	DBM-400/30R	156	6.14	60	2.36	30	1.18	14	0.551	1.9	4.2	C-245YYY	C-686YYY
DeltaPro-500HRA	DBM-500/30R	158	6.22	95	3.74	35	1.38	14	0.551	3.2	7.1	C-246YYY	C-687YYY

DeltaPro-120HRA/HRB

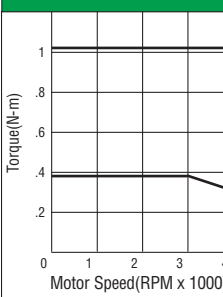

DeltaPro-200HRA/HRB

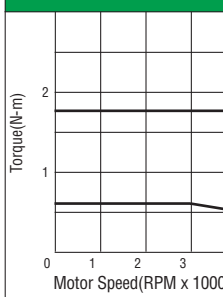

DeltaPro-400LRA

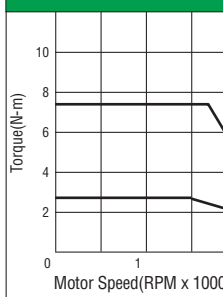

DeltaPro-400HRA

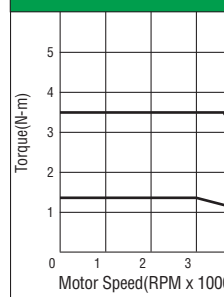

DeltaPro-500HRA

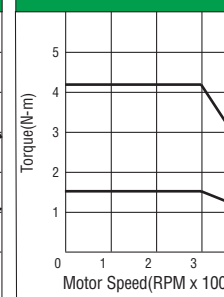

All specifications are at nominal line voltage

DeltaPro DPro-17.5 Motor and Integrated Drive/Controller Packages

DeltaPro Package	Motor Part Number	DeltaPro Part Number	Power Output Watts	Rated Speed RPM	Max Speed RPM	Rated Torque			Peak Torque			Rotor Inertia		
						N-M	Lb-in	Lb-ft	N-M	Lb-in	Lb-ft	Kg-cm ²	Lb-in-sec ²	Lb-ft-sec ²
DeltaPro-800LRA	DBM-800/15R	DPro-17.5/RA	800	1500	2000	5.10	45.14	3.76	11.00	97.36	8.11	1.890	0.001673	0.0001394
DeltaPro-800HRA	DBM-800/30R	DPro-17.5/RA	800	3000	4000	2.55	22.57	1.88	7.80	69.04	5.75	0.760	0.000673	0.0000561
DeltaPro-1000LRA	DBM-1000/15R	DPro-17.5/RA	1000	1500	2000	6.37	56.38	4.70	15.40	136.30	11.36	2.570	0.002275	0.0001896
DeltaPro-1000HRA	DBM-1400/30R	DPro-17.5/RA	1000	3000	4000	3.10	27.44	2.29	7.14	63.19	5.27	1.890	0.001673	0.0001394

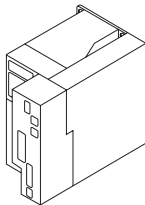

Dimensions

	in.	(mm.)
Panel height	6.70	170
Panel width	6.12	156
Depth off panel	8.00	203

DeltaPro Package	Motor Part Number	Motor Length		Mounting Face (Sq)		Shaft Length		Shaft Diameter		Motor Weight		Resolver Cable	Motor Cable
		mm	in	mm	in	mm	in	mm	in	kg	lbs		
DeltaPro-800LRA	DBM-800/15R	178	7.01	130	5.12	45	1.77	19	0.748	6.2	13.7	C-246YYY	C-688YYY
DeltaPro-800HRA	DBM-800/30R	190	7.48	95	3.74	45	1.77	19	0.748	4.5	9.9	C-246YYY	C-687YYY
DeltaPro-1000LRA	DBM-1000/15R	196	7.72	130	5.12	45	1.77	19	0.748	7.8	17.2	C-246YYY	C-688YYY
DeltaPro-1000HRA	DBM-1400/30R	178	7.01	130	5.12	45	1.77	19	0.748	6.2	13.7	C-246YYY	C-688YYY

DeltaPro-800LRA

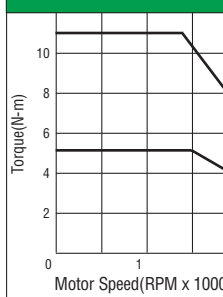

DeltaPro-800HRA

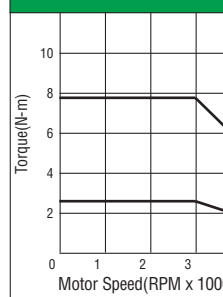

DeltaPro-1000LRA

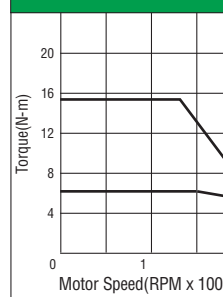

DeltaPro-1000HRA

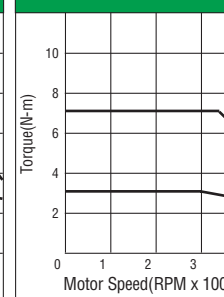

All specifications are at nominal line voltage

DeltaPro DPro-35 Motor and Integrated Drive/Controller Packages

DeltaPro Package	Motor Part Number	DeltaPro Part Number	Power Output Watts	Rated Speed RPM	Max Speed RPM	Rated Torque			Peak Torque			Rotor Inertia		
						N-M	Lb-in	Lb-ft	N-M	Lb-in	Lb-ft	Kg-cm ²	Lb-in-sec ²	Lb-ft-sec ²
DeltaPro-1400HRA	DBM-1400/30R	DPro-35/RA	1400	3000	4000	4.46	39.47	3.29	10.00	88.51	7.38	1.890	0.001673	0.0001394
DeltaPro-1500LRA	DBM-1500/15R	DPro-35/RA	1500	1500	2000	9.55	84.52	7.04	23.00	203.57	16.96	4.100	0.003629	0.0003024
DeltaPro-1800HRA	DBM-1800/30R	DPro-35/RA	1800	3000	4000	5.73	50.71	4.23	14.00	123.91	10.33	2.570	0.002275	0.0001896
DeltaPro-2200LRA	DBM-2600/15R	DPro-35/RA	2200	1500	2000	14.08	124.62	10.38	31.66	280.21	23.35	15.200	0.013453	0.0011211

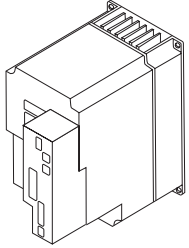

Dimensions

	in.	(mm.)
Panel height	9.84	250
Panel width	5.31	135
Depth off panel	9.97	253

All specifications are at nominal line voltage

DeltaPro Package	Motor Part Number	Motor Length		Mounting Face (Sq)		Shaft Length		Shaft Diameter		Motor Weight		Resolver Cable	Motor Cable
		mm	in	mm	in	mm	in	mm	in	kg	lbs		
DeltaPro-1400HRA	DBM-1400/30R	178	7.01	130	5.12	45	1.77	19	0.748	6.2	13.7	C-246YYY	C-689YYY
DeltaPro-1500LRA	DBM-1500/15R	236	9.29	130	5.12	55	2.17	24	0.945	10.9	24.0	C-246YYY	C-689YYY
DeltaPro-1800HRA	DBM-1800/30R	196	7.72	130	5.12	45	1.77	19	0.748	7.8	17.2	C-246YYY	C-689YYY
DeltaPro-2200LRA	DBM-2600/15R	238	9.37	180	7.09	79	3.11	35	1.378	20.0	44.1	C-246YYY	C-690YYY

DeltaPro-1400HRA

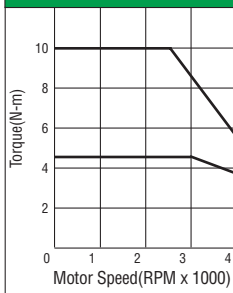

DeltaPro-1500LRA

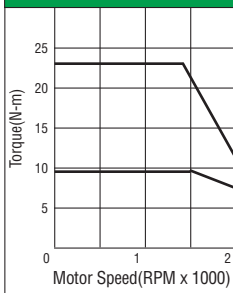

DeltaPro-1800HRA

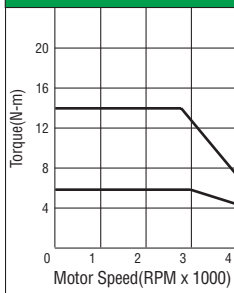

DeltaPro-2200LRA

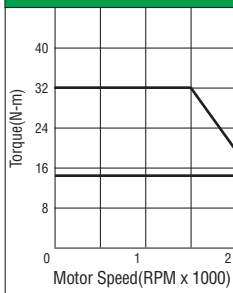

DeltaPro DPro-50 Motor and Integrated Drive/Controller Packages

DeltaPro Package	Motor Part Number	DeltaPro Part Number	Power Output Watts	Rated Speed RPM	Max Speed RPM	Rated Torque			Peak Torque			Rotor Inertia		
						N-M	Lb-in	Lb-ft	N-M	Lb-in	Lb-ft	Kg-cm ²	Lb-in-sec ²	Lb-ft-sec ²
DeltaPro-2400HRA	DBM-2400/30R	DPro-50/RA	2400	3000	4000	7.64	67.62	5.63	21.00	185.87	15.49	4.100	0.003629	0.0003024
DeltaPro-2600LRA	DBM-2600/15R	DPro-50/RA	2600	1500	2000	16.60	146.92	12.24	38.00	336.33	28.03	15.200	0.013453	0.0011211
DeltaPro-2900LRA	DBM-3700/15R	DPro-50/RA	2900	1500	2000	18.58	164.45	13.70	46.67	413.06	34.42	22.300	0.019737	0.0016448
DeltaPro-3000HRA	DBM-3700/30R	DPro-50/RA	3000	3000	4000	9.56	84.61	7.05	23.18	205.16	17.10	15.200	0.013453	0.0011211

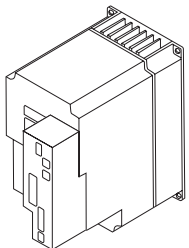

Dimensions

	in.	(mm.)
Panel height	9.84	250
Panel width	5.31	135
Depth off panel	9.97	253

All specifications are at nominal line voltage

DeltaPro Package	Motor Part Number	Motor Length		Mounting Face (Sq)		Shaft Length		Shaft Diameter		Motor Weight		Resolver Cable	Motor Cable
		mm	in	mm	in	mm	in	mm	in	kg	lbs		
DeltaPro-2400HRA	DBM-2400/30R	236	9.29	130	5.12	55	2.17	24	0.945	10.9	24.0	C-246YYY	C-689YYY
DeltaPro-2600LRA	DBM-2600/15R	238	9.37	180	7.09	79	3.11	35	1.378	20.0	44.1	C-246YYY	C-690YYY
DeltaPro-2900LRA	DBM-3700/15R	288	11.34	180	7.09	79	3.11	35	1.378	27.0	59.5	C-246YYY	C-691YYY
DeltaPro-3000HRA	DBM-3700/30R	236	9.29	180	7.09	79	3.11	35	1.378	20.0	44.1	C-246YYY	C-691YYY

DeltaPro-2400HRA

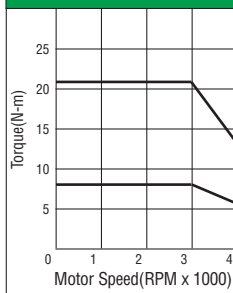

DeltaPro-2600LRA

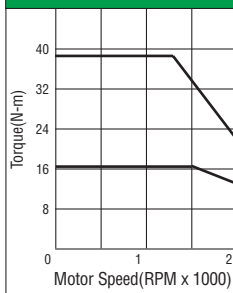

DeltaPro-2900LRA

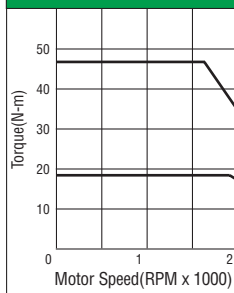

DeltaPro-3000HRA

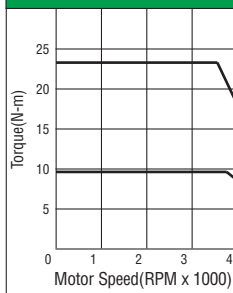

DeltaPro DPro-70 Motor and Integrated Drive/Controller Packages

DeltaPro Package	Motor Part Number	DeltaPro Part Number	Power Output Watts	Rated Speed RPM	Max Speed RPM	Rated Torque			Peak Torque			Rotor Inertia		
						N-M	Lb-in	Lb-ft	N-M	Lb-in	Lb-ft	Kg-cm ²	Lb-in-sec ²	Lb-ft-sec ²
DeltaPro-3700LRA	DBM-3700/15R	DPro-70/RA	3700	1500	2000	23.60	208.88	17.41	60.00	531.05	44.25	22.300	0.019737	0.0016448
DeltaPro-3700HRA	DBM-3700/30R	DPro-70/RA	3700	3000	4000	11.80	104.44	8.70	29.80	263.75	21.98	15.200	0.013453	0.0011211
DeltaPro-4300HRA	DBM-5500/30R	DPro-70/RA	4300	3000	4000	13.76	121.79	10.15	36.15	319.95	26.66	22.300	0.019737	0.0016448

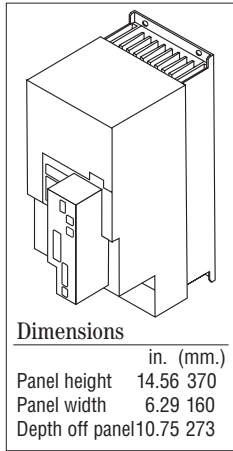

Dimensions

	in. (mm.)
Panel height	14.56 370
Panel width	6.29 160
Depth off panel	10.75 273

All specifications are at nominal line voltage

DeltaPro Package	Motor Part Number	Motor Length		Mounting Face (Sq)		Shaft Length		Shaft Diameter		Motor Weight		Resolver Cable	Motor Cable
		mm	in	mm	in	mm	in	mm	in	kg	lbs		
DeltaPro-3700LRA	DBM-3700/15R	288	11.34	180	7.09	79	3.11	35	1.378	27.0	59.5	C-246YYY	C-691YYY
DeltaPro-3700HRA	DBM-3700/30R	236	9.29	180	7.09	79	3.11	35	1.378	20.0	44.1	C-246YYY	C-691YYY
DeltaPro-4300HRA	DBM-5500/30R	288	11.34	180	7.09	79	3.11	35	1.378	27.0	59.5	C-246YYY	C-692YYY

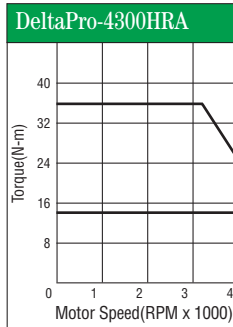
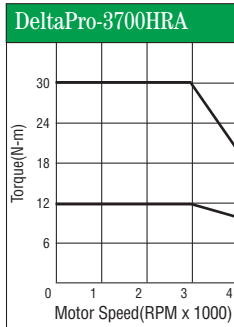
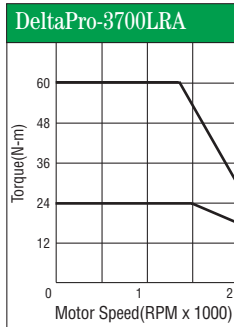

DeltaPro DPro-115 Motor and Integrated Drive/Controller Packages

DeltaPro Package	Motor Part Number	DeltaPro Part Number	Power Output Watts	Rated Speed RPM	Max Speed RPM	Rated Torque			Peak Torque			Rotor Inertia		
						N-M	Lb-in	Lb-ft	N-M	Lb-in	Lb-ft	Kg-cm ²	Lb-in-sec ²	Lb-ft-sec ²
DeltaPro-5000LRA	DBM-5000/15R	DPro-115/RA	5000	1500	2000	31.80	281.45	23.45	76.00	672.66	56.05	30.000	0.026552	0.0022127
DeltaPro-5500HRA	DBM-5500/30R	DPro-115/RA	5500	3000	4000	17.50	154.89	12.91	47.00	415.99	34.67	22.300	0.019737	0.0016448
DeltaPro-6500HRA	DBM-6500/30R	DPro-115/RA	6500	3000	4000	20.70	183.21	15.27	60.00	531.05	44.25	30.000	0.026552	0.0022127

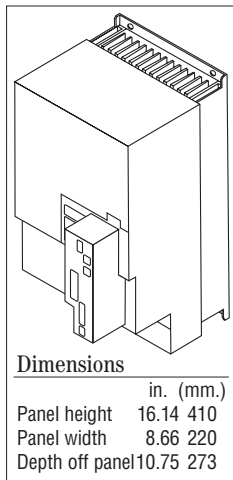

Dimensions

	in. (mm.)
Panel height	16.14 410
Panel width	8.66 220
Depth off panel	10.75 273

All specifications are at nominal line voltage

DeltaPro Package	Motor Part Number	Motor Length		Mounting Face (Sq)		Shaft Length		Shaft Diameter		Motor Weight		Resolver Cable	Motor Cable
		mm	in	mm	in	mm	in	mm	in	kg	lbs		
DeltaPro-5000LRA	DBM-5000/15R	338	13.31	180	7.09	79	3.11	35	1.378	34.0	75.0	C-246YYY	C-692YYY
DeltaPro-5500HRA	DBM-5500/30R	288	11.34	180	7.09	79	3.11	35	1.378	27.0	59.5	C-246YYY	C-692YYY
DeltaPro-6500HRA	DBM-6500/30R	338	13.31	180	7.09	79	3.11	35	1.378	34.0	75.0	C-246YYY	C-692YYY

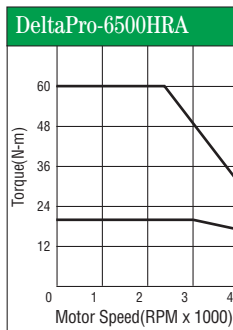
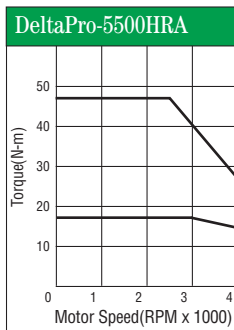
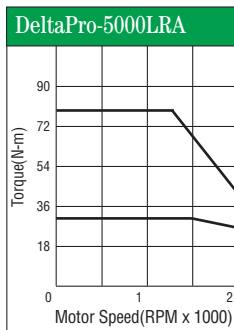

We produce a wide range of motion control products and services, and we specialize in factory-floor systems for demanding industrial applications. We support our systems completely,

and guarantee system-level performance in writing. If you have a tough motion control problem, give us a call. We're very easy to do business with.



Industrial Indexing Systems
626 Fishers Run
Victor, New York 14564
Telephone (585) 924-9181
Facsimile (585) 924-2169
email: info@iis-servo.com
web: www.iis-servo.com

Need Help With Your Motion Control?

These products are a small portion of our offerings. Choose pre-engineered systems including controller, motor, drive, feedback devices, power supply and cables, in single or multi-axis versions, either pre-programmed

or user-programmable. Or choose individual components like motors, controllers, drives, power supplies, operator interfaces, NEMA enclosures and cabling. For tough applications, we can custom engineer a system to your exact specifications.

And all IIS systems are pre-tested so they're ready to go, and all include comprehensive troubleshooting and wiring documentation for simple installation and quick start-up.

DeltaPro and Delta Series are trademarks of Industrial Indexing Systems. DeviceNet is a trademark of ODVA.

This data is subject to change without notice.