

**IB-11B013**

**MOTION CONTROL SYSTEMS, MSC SERIES**

**JANUARY 1997**

# **EFC-100**

# **ENCODER/FIBER OPTIC CONVERTER**

## **INSTRUCTION BOOK**

**INDUSTRIAL INDEXING SYSTEMS, Inc.**

**Revision - E**  
Approved By:

Proprietary information of Industrial Indexing Systems, Inc. furnished for customer use only.  
No other uses are authorized without the prior written permission of  
**Industrial Indexing Systems, Inc.**

# EFC-100

## Encoder to Fiber-Optic Converter

### I. INTRODUCTION

The EFC-100 (Encoder/Fiber-Optic Converter) is a DIN rail mounted assembly to be used with MSC-850 and MSC-250 System Units. Power supplied to the EFC-100 is 115V AC. See Section III on specifications.

The EFC-100 is connected to an encoder with IIS cable part number C-300YYY (see 2). Encoder channel operation is verified by Red LEDs labeled; CH1, CH2, M (see 1). There is a 16-position selector switch, near the three LEDs, to select the encoder line count (see Table 1). Fiber Optic cable, IIS part number C-966YYY (see 3), links the EFC-100 to an MCF-850.

### II. OPERATION

The EFC-100 takes encoder positional information and transmits this information serially through the C-966YYY fiber optic cable. Typically, only one fiber optic transmitter (U9) is present on the EFC-100, but, depending on the application, up to four fiber optic transmitters are available (see 1). All of the fiber optic transmitters transfer the same data.

On power up, information is not transmitted until a marker pulse is observed. At this time, two bytes of positional information are transmitted every millisecond. The 16-position selector switch (see 1) determines the encoder line count according to the information in given in Table 1. A single red LED (see 1) is lit when a marker error is present. Marker errors consist of a missing marker or missing encoder counts.

### III. SPECIFICATIONS

#### A. Environment

Operating Temperature:	0 to 60 C
Ventilation:	Unit must have 5 inches of free air flow above
Humidity:	30% to 90% relative (non-condensing)

**B. Size**

Length: 9.80 in. Max.  
Width: 3.20 in. Max.  
Height: 2.70 in. Ref.

**C. Power Requirements**

Input Voltage: 115V AC  $\pm$  10  
Frequency: 50-60 Hz  
Input Current: 0.5 Amp Maximum

**D. Encoder Type**

Voltage: +5V  
Input Type: Differential

**E. Fiber Optic Link Cable**

IIS Part No.: C-966YYY  
Max. Length: 100ft (30.5) Max.

**Table 1** Configuration Switch and Code Bit Settings

Configuration Switch Settings	Encoder Type		Controller Type
	Line Count	Bits per Revolution	
0	1024	4096	MSC
1	512	2048	MSC
2	2048	8192	MSC
3	4096	16384	MSC
4	1000	4000	MSC
5	2000	8000	MSC
6	1024	4096	MSC
7	1024	4096	MSC
8	1024	4096	DELTAMAX
9	512	2048	DELTAMAX
A	2048	8192	DELTAMAX
B	4096	16384	DELTAMAX
C	1000	4000	DELTAMAX
D	2000	8000	DELTAMAX
E	1024	4096	DELTAMAX
F	1024	4096	DELTAMAX

## IV. FUNCTIONAL TEST

1. Set a Multimeter to a scale to read 115V AC.
2. Turn on the system power.
3. Verify 115V AC  $\pm$  10% from P2-N to P2-H.
4. If the voltage is within specification, then continue with the next step. If the voltage is out of specification, then correct the voltage supply before proceeding.
5. Set a multimeter to the 10V DC scale.
6. Connect the meter leads to P1-10 and P1-11 (green and black wires of C-300YYY cable, (see 2)).
7. The meter should indicate 5V DC  $\pm$  0.25V DC.
8. If an out of specification reading is still obtained, replace the EFC-100. If readings are correct, then go on to the next step
9. With the 12-pin connector P1 connected to the EFC-100, connect the meter leads to P1-1 and P1-2 (see 2).
10. Move the encoder shaft to find two different voltages; one being 0.8V DC or less, and the other being 2.5V DC or more. If an out of specification reading is obtained, then replace the encoder.
11. With P1 connected to the EFC-100 connect the meter leads to P1-4 and P1-5 (see 2).
12. Move the encoder shaft to find two different voltages; one being 0.8V DC or less, and the other being 2.5V DC or more. If an out of specification reading is obtained, then replace the encoder.
13. With P1 connected to the EFC-100 connect the meter leads to P1-7 and P1-8 (see 2).
14. Move the encoder shaft to find two different voltages; one being 0.8V DC or less, and the other being 2.5V DC or more. If an out of specification reading is obtained, then replace the encoder.
15. If the readings are correct, then go to the next step.
16. Disconnect the Fiber Optic Cable from the Fiber Optic Transmitter on the EFC-100.
17. Verify a red glow emminating from the Fiber Optic Transmitter.

18. If there is no glow, then replace the EFC-100. If a red glow is present, go on to the next step.
19. Reconnect the Fiber Optic Cable to the Fiber Optic Transmitter on the EFC-100.
20. Disconnect the opposite end of the Fiber Optic Cable from the motion controller.
21. Verify a red glow emanating from the end of the Fiber Optic Cable.
22. If there is no glow, then replace the Fiber Optic Cable. If a red glow is present, go to the next step.
23. Slowly rotate the encoder shaft. The CH1 and CH2 LEDs on the EFC-100 should toggle on and off with slow rotations of the shaft (see 1). The M LED should pulse on at 0 .

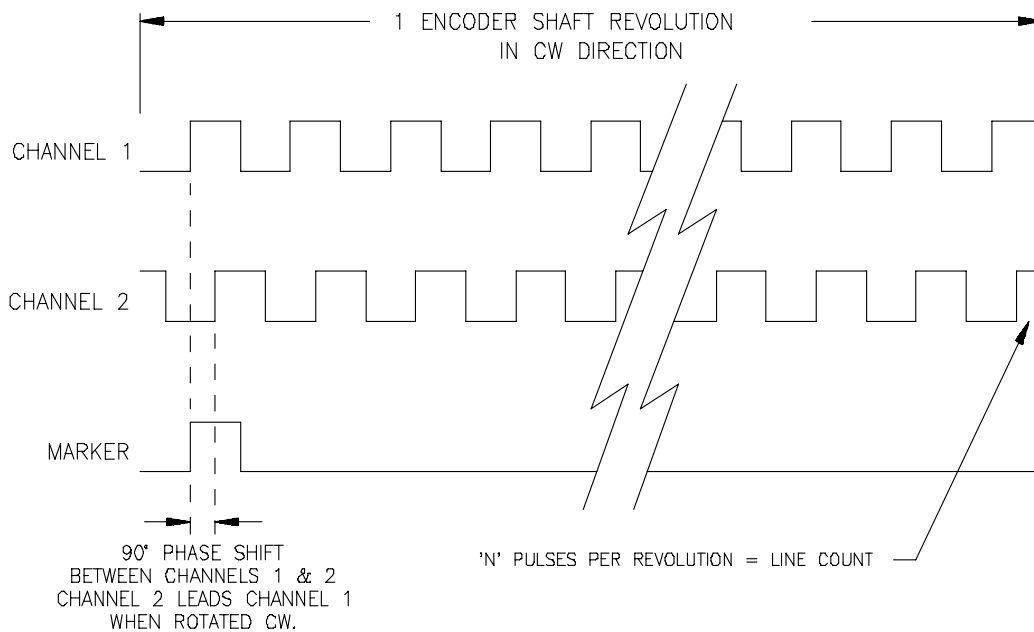

**Figure 1 - Standard Encoder Output Channels Relationship**

24. If the LEDs are not working properly, then replace the EFC-100.
25. If the LED tests are good, then any other problems that occur may be from the Fiber Optic Receiver end of the Motion Controller, or the Motion Control software.
26. Turn off power to the system.

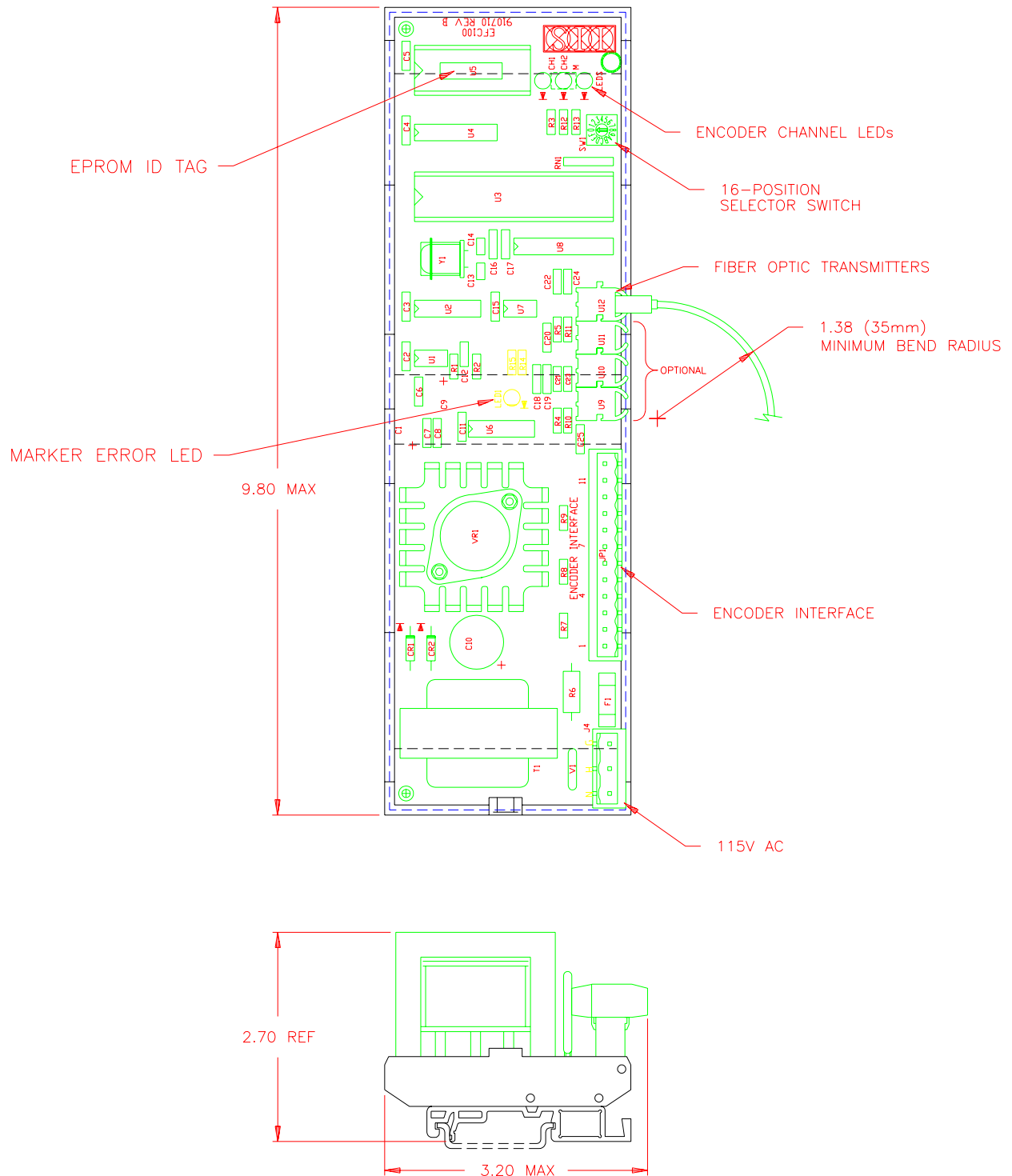
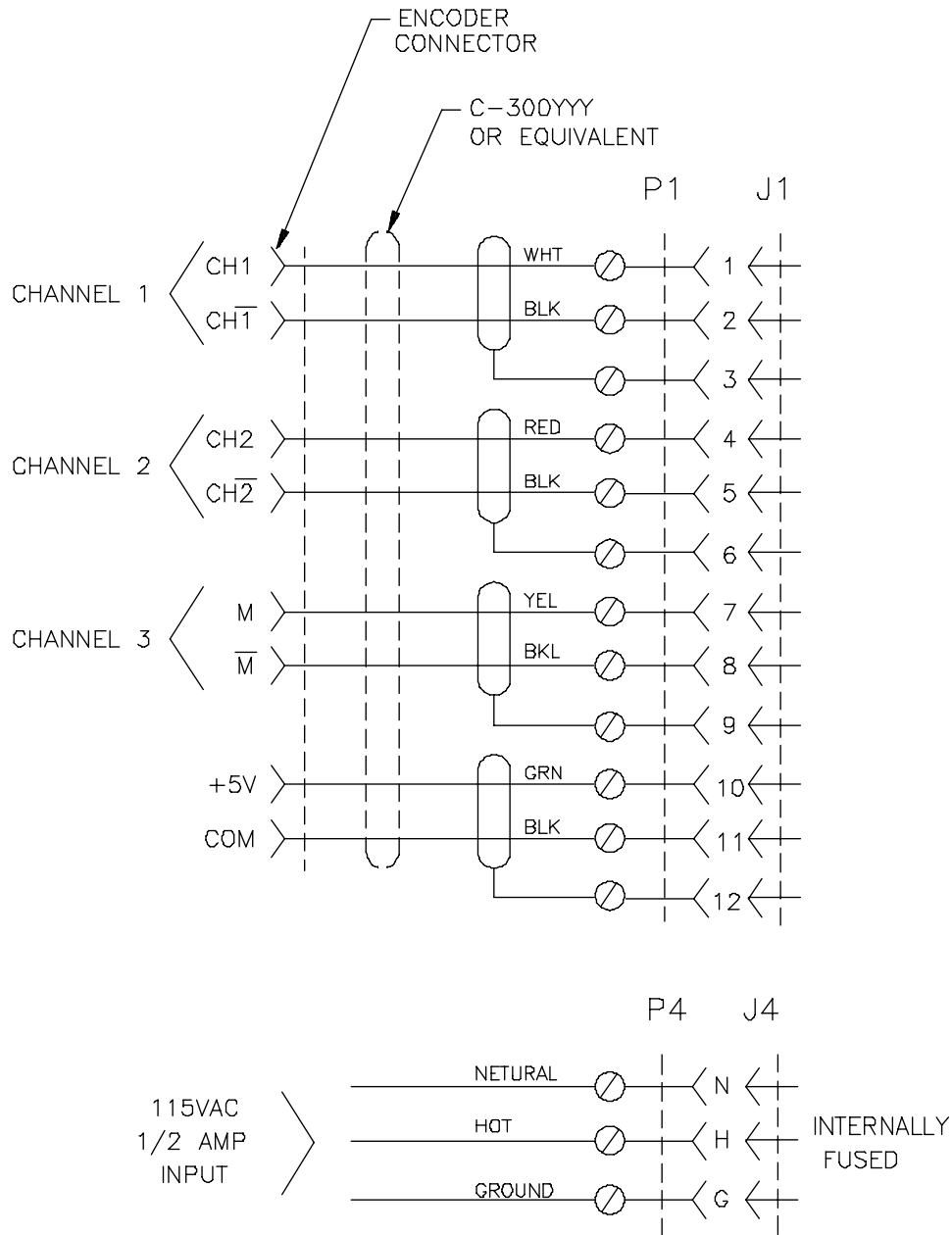
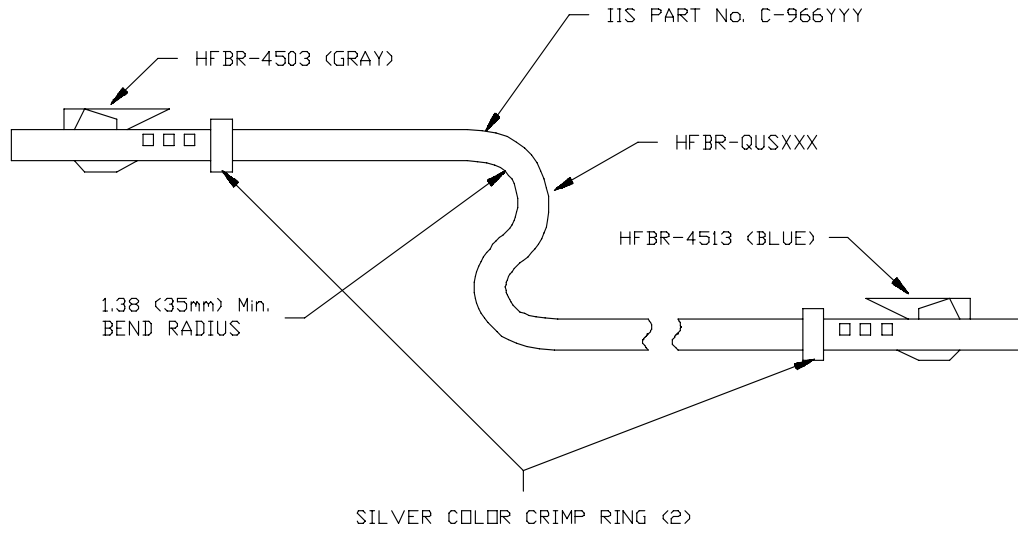

Figure 2 - EFC-100 Layout



**Figure 2 - Connection Interconnection**



PREMADE CABLES

HEWLETT-PACKARD PART No.	LENGTH (METERS)	IIS PART No.	LENGTH (FEET)
HFBR-QLS001	1	C-966003	3
HFBR-QLS005	5	C-966015	15
HFBR-QLS010	10	C-966030	30
HFBR-QLS020	20	C-966060	60

NOTE: CABLE LENGTH NOT TO EXCEED 100 FT (30M)

**Figure 3 - Fiber Optic Link Cable, C-966YYY**



IB-11B013

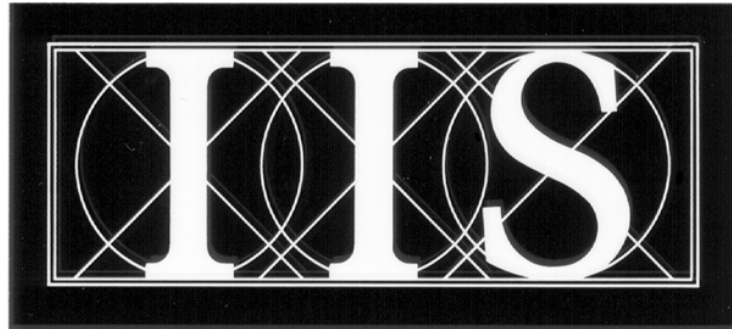

**INDUSTRIAL  
INDEXING SYSTEMS  
INC.**

**626 FISHERS RUN  
VICTOR, NEW YORK 14564**

**(585) 924-9181  
FAX: (585) 924-2169**

PRINTED IN USA  
© 2001